



齒條 Racks



公司簡介

原億昌機械將近四十年的生產經驗，擁有 ISO 9001 認證，與經濟部工研院產學合作，因應目前全球智能製造的趨勢，提供傳動系列零配件與設備，包含齒條（排齒）、導軌齒條、齒輪、滾輪、行星減速機和消除減速機等產品。

廣大客群包含各行業領域例如：CNC 機台、工具母機、木工機、印刷機、切割機、龍門銑床、磨床、鑽床、彎管機、機器人手臂、自動化倉儲設備、自動上下料軌道、沙灘車、汽車、航空母艦、半導體設備廠、起重機等。

原億昌產品優良，於 2015 年榮獲台灣第 12 屆國家品牌玉山獎，傑出企業類；2016 年極度精密齒條齒輪組，榮獲第十三屆國家品牌玉山獎最佳產品獎，與金炬獎十大績優商品獎。

原億昌以自有品牌 YYC 行銷市場，"You drive, You Control!" 你驅動，你掌控！為企業標語，目標是客戶所使用的驅動零件品質卓越，效能皆在客戶的掌控之中，將產品定位於中高端市場，已經行銷近五十多個國家，提供更多客戶滿意，是我們持續努力的目標。

COMPANY PROFILE

Yuan Yi Chang Machinery has 40 years of experience, with ISO 9001 certificate and work projects with Industrial Technology Research Institute. Corresponding to smart manufacturing trend globally, YYC offers different series of transmission parts and equipment including Rack, Guideway Rack, Pinion, Roller, Planetary Reducers, Backlash Free Reducers.

Our major clients include all kinds of industries and fields such as CNC machines, machine centers, wood-cutting machines, printing machines, cutting machines, gantry milling machines, grinding machines, drilling machines, bending machines, robotic arms, automatic storage equipment, automatic upload & unload track, ATV, aircraft carrier, semiconductor plant, cranes, and so on.

YYC has excellent quality capability. In 2015, we earned Best Enterprise of National Brand Yu-Shan Award. In 2016, our Ultra High Precision Rack and Pinion won Best Products of National Brand Yu-Shan Award and Golden Torch Prize.

Yuan Yi Chang has marketed by brand name "YYC" which means "You drive, You Control!" Every driven part with outstanding quality, so the performance is under customer's control. Products are target on middle to high end markets. Currently, we are exporting nearly 50 countries. To have more customers' satisfactions is our continuous goal.



世界主要齒條與齒輪標準規範

World Major Standard Specification of Racks and Pinions

簡稱 Specification	中文名稱	Full Name
AGMA	美國齒輪製造協會	American Gear Manufacturers Association
DIN	德國標準化學會	Deutsches Institut für Normung
ISO	國際標準化組織	International Organization for Standardization
JIS	日本工業標準	Japanese Industrial Standards

精度等級對照表

Quality Grade Comparison Table

規格 Standard	精 度 等 級 / Quality Grade											
ISO	1	2	3	4	5	6	7	8	9	10	11	12
DIN		2	3	4	5	6	7	8	9	10	11	12
AGMA		15	14	13	12	11	10	9	8	7	6	5
JIS				0	1	2	3	4	5	6	7	8
JIS N				N4	N5	N6	N7	N8	N9	N10		

以節距誤差比較：F_p f_p

Compared with Pitch Error: F_p f_p

齒條目錄 Contents of Racks

齒條 Rack

DIN	型號 Code	精度等級 DIN 3962	材 料 Material	齒型 Type	齒面處理 Teeth Treatment	硬度處理 Hardness	鑽 孔 Mounted Holes	模 數 Module	頁碼 Page
DIN	CHTGH	DIN 5	S45C	斜齒右斜 Helical Right Hand 19°31'42"	齒面研磨 Teeth Ground	熱處理 Hardened HRC 50°-55°	鑽孔 Holes	1.5, 2, 2.5, 3, 4, 5, 6, 8	P.6
	CHTGH	DIN 6	S45C			熱處理 Hardened HRC 50°-55°		1.5, 2, 2.5, 3, 4, 5, 6, 8, 10	P.7
	MHTG	DIN 6	SCM440			*		1.5, 2, 2.5, 3, 4, 5, 6, 8	P.8
	CHTM	DIN 8	S45C		*	1.5, 2, 3, 4, 5, 6, 8, 10		P.9	
	CHTMQ	DIN 8	S45C		精銑 Milled	調質 HRC18°-22° Quenched & Tempered		1.5, 2, 3, 4, 5, 6, 8, 10	P.10
	CHTMH	DIN 10	S45C		熱處理 Hardened HRC 50°-55°	1.5, 2, 3, 4, 5, 6, 8, 10		P.11	
	CSTGH	DIN 5	S45C	直齒 Straight	齒面研磨 Teeth Ground	熱處理 /Hardened HRC 50°-55		2, 3, 4, 5	P.12
	CSTGH	DIN 6	S45C			熱處理 /Hardened HRC 50°-55		1.5, 2, 2.5, 3, 4, 5, 6, 8	P.13
	CSTM	DIN 8	S45C			*		1.5, 2, 3, 4, 5, 6, 8, 10	P.14
	CSTMQ	DIN 8	S45C		精銑 Milled	調質 Quenched&Tempered HRC 18°-22°		1.5, 2, 3, 4, 5, 6, 8, 10	P.15
	CSTMH	DIN 10	S45C		熱處理 Hardened HRC 50°-55°	1.5, 2, 3, 4, 5, 6, 8, 10		P.16	

JIS	型號 Code	精度等級 JIS	材 料 Material	齒型 Type	齒面處理 Teeth Treatment	硬度處理 Hardness	鑽 孔 Mounted Holes	模 數 Module	頁碼 Page
JIS	MHTGQ	JIS 1	SCM440	斜齒右斜 Helical 20°30'	齒面研磨 Teeth Ground	調質 HRC18°-22° Quenched & Tempered	鑽孔 Holes	1, 1.5, 2, 2.5, 3	P.17
	CHTM	JIS 4	S45C	斜齒右斜 Helical 15°	精銑 Milled	*	有 / 無鑽孔 with/out Holes	2, 3	P.18
	CSTGH	JIS 2	S45C	直齒 Straight	齒面研磨 Teeth Ground	熱處理 Hardened HRC 50°-55°	有 / 無鑽孔 with/out Holes	1, 1.5, 2, 2.5, 3, 4, 5, 6	P.19
	MSTMQ	JIS 4	SCM440		調質 HRC18°-22° Quenched & Tempered	有 / 無鑽孔 with/out Holes	1.5, 2, 2.5, 3, 4, 5, 6	P.20	
	CSTM	JIS 4	S45C		精銑 Milled	*	有 / 無鑽孔 with/out Holes	1, 1.5, 2, 2.5, 3, 4, 5, 6	P.21
	CSTMH	JIS 5	S45C		熱處理 Hardened HRC 50°-55°	有 / 無鑽孔 with/out Holes	1.5, 2, 2.5, 3, 4, 5, 6	P.22	

CP	型號 Code	精度等級 JIS	材 料 Material	齒型 Type	齒面處理 Teeth Treatment	硬度處理 Hardness	鑽 孔 Mounted Holes	周節 CP	頁碼 Page
CP	MSTGQ-CP	JIS 1	SCM440	直齒 Straight	齒面研磨 Teeth Ground	調質 HRC18°-22° Quenched & Tempered	有 / 無鑽孔 with/out Holes	5, 10	P.23
	MSTGH-CP	JIS 1	SCM440			熱處理 Hardened HRC 55°-58°	有 / 無鑽孔 with/out Holes	5, 10	P.24
	CSTM-CP	JIS 4	S45C		精銑 Milled	*	有 / 無鑽孔 with/out Holes	5, 10, 15, 20	P.25

齒條型號說明 Rack Code Instruction

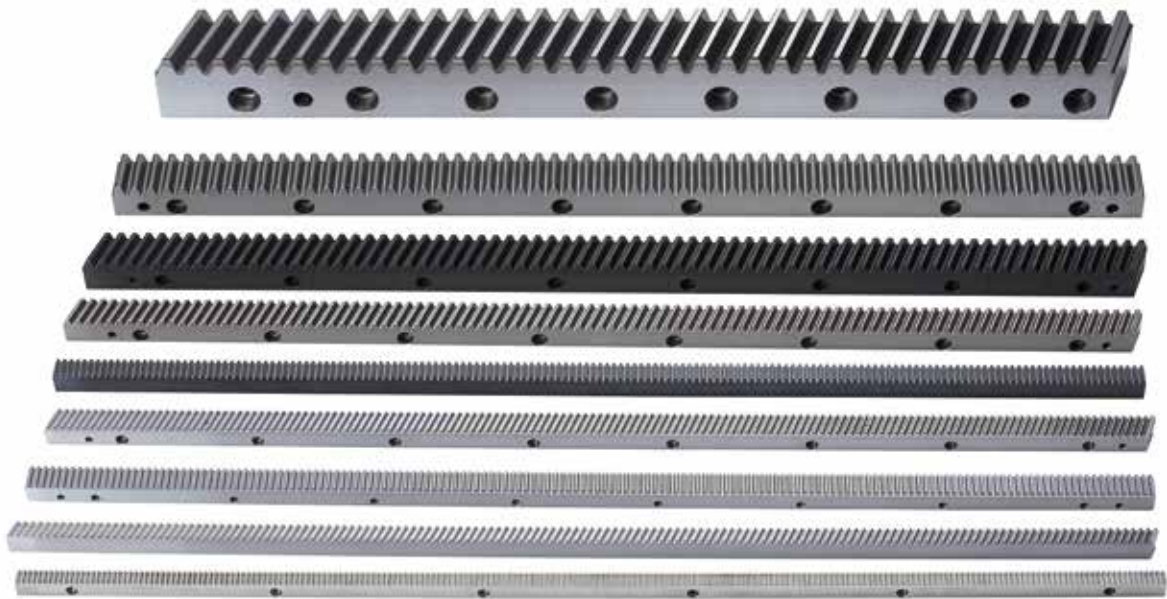

1st	2nd	3rd	4th	5th	6th	7th	8th
材料 Material	齒型 Type	棒型 Shape	齒面處理 Teeth Treatment	硬度處理 Hardness	模數 Module	長度 Length	等級 Grade
C	S	T	G	H	020	10	DIN JIS
C= 中碳鋼 M= 合金鋼	S= 直齒 H= 斜齒	T= 四角棒	M= 精梳 G= 齒研	Q= 調質 H= 硬化處理	M1.5~M10	05=500mm 10=1000mm 15=1500mm 20=2000mm	DIN 5-10 JIS 1-5
C= Carbon Steel =S45C M= Alloy Steel =SCM440	S= Straight H= Helical	T= Tetragon	M= Milled G= Ground	H= Hardened Q= Quenched & Tempered			

備註：長度、鑽孔、材質、表面處理（噴砂、磷酸鹽、染黑、研磨）等特殊需求，皆可客製。

Remarks: Lengths, holes, materials, surface treatments (sandblasted, phosphated, Black-coated, sides ground) and other requirements all could be customized.

CHTGH-DIN5

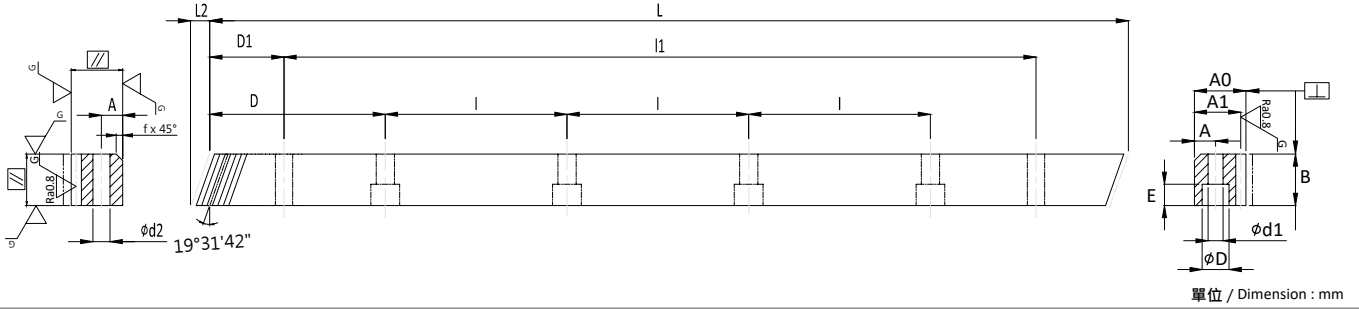

斜齒 Helical
DIN

系列 CHTGH-DIN5 斜齒齒研齒條
品質等級 DIN 5

Series CHTGH-DIN5 Helical Teeth Ground Racks
Quality Grade DIN 5

材料 S45C
右旋角 19°31'42"
硬度 HRC 50~55°
硬化處理後四面研磨與齒研
總齒距誤差 : $F_p / 1000 \leq 0.026$ mm
室溫在攝氏 25° 為準

Material S45C
Right Hand Angle 19°31'42"
Hardness HRC 50~55°
Ground on all sides after hardening.
Total Pitch Error: $F_p / 1000 \leq 0.026$ mm
Room Temperature is 25°C

單位 / Dimension : mm

型號 Code	模數 Module	L	L2	齒數 No. of Teeth	B	A0	A1	D	I	孔數 No. of Holes	A	φd1	φD	E	D1	I1	φd2	f	F _{ta} kN	KG
CHTGH01505-DIN5	1.5	500.00	6.70	100	19	19	17.5	62.5	125	4	8	7	11	7	31.7	436.60	5.7	1.5	6.87	1.3
CHTGH01510-DIN5	1.5	1000.00	6.70	200	19	19	17.5	62.5	125	8	8	7	11	7	31.7	936.60	5.7	1.5	6.97	2.6
CHTGH02005-DIN5	2	500.00	8.50	75	24	24	22.0	62.5	125	4	8	7	11	7	31.7	436.60	5.7	2	11.46	2.1
CHTGH02010-DIN5	2	1000.00	8.50	150	24	24	22.0	62.5	125	8	8	7	11	7	31.7	936.60	5.7	2	11.68	4.1
CHTGH02505-DIN5	2.5	500.00	8.50	60	24	24	21.5	62.5	125	4	9	7	11	7	31.7	436.60	5.7	2	14.20	2.1
CHTGH02510-DIN5	2.5	1000.00	8.50	120	24	24	21.5	62.5	125	8	9	7	11	7	31.7	936.60	5.7	2	14.52	4.1
CHTGH03005-DIN5	3	500.00	10.30	50	29	29	26.0	62.5	125	4	9	10	15	9	35	430.00	7.7	2	20.41	3.0
CHTGH03010-DIN5	3	1000.00	10.30	100	29	29	26.0	62.5	125	8	9	10	15	9	35	930.00	7.7	2	20.96	6.0
CHTGH04005-DIN5	4	506.67	13.80	38	39	39	35.0	62.5	125	4	12	10	15	9	33.3	433.00	7.7	2	36.11	5.5
CHTGH04010-DIN5	4	1000.00	13.80	75	39	39	35.0	62.5	125	8	12	10	15	9	33.3	933.40	7.7	2	37.24	10.8
CHTGH05005-DIN5	5	500.00	17.40	30	49	39	34.0	62.5	125	4	12	14	20	13	37.5	425.00	11.7	3	55.95	6.8
CHTGH05010-DIN5	5	1000.00	17.40	60	49	39	34.0	62.5	125	8	12	14	20	13	37.5	925.00	11.7	3	57.97	13.6
CHTGH06005-DIN5	6	500.00	20.90	25	59	49	43.0	62.5	125	4	16	18	26	17	37.5	425.00	15.7	3	79.91	10.3
CHTGH06010-DIN5	6	1000.00	20.90	50	59	49	43.0	62.5	125	8	16	18	26	17	37.5	925.00	15.7	3	83.07	20.5
CHTGH08005-DIN5	8	480.00	28.00	18	79	79	71.0	60.0	120	4	25	22	33	21	120	240.00	19.7	4	139.40	21.3
CHTGH08010-DIN5	8	960.00	28.00	36	79	79	71.0	60.0	120	8	25	22	33	21	120	720.00	19.7	4	145.83	42.6

※ 重量僅供參考，實重須經實秤為準。

※ Weight only for reference. Actual scale should be Weighing.

CHTGH-DIN6

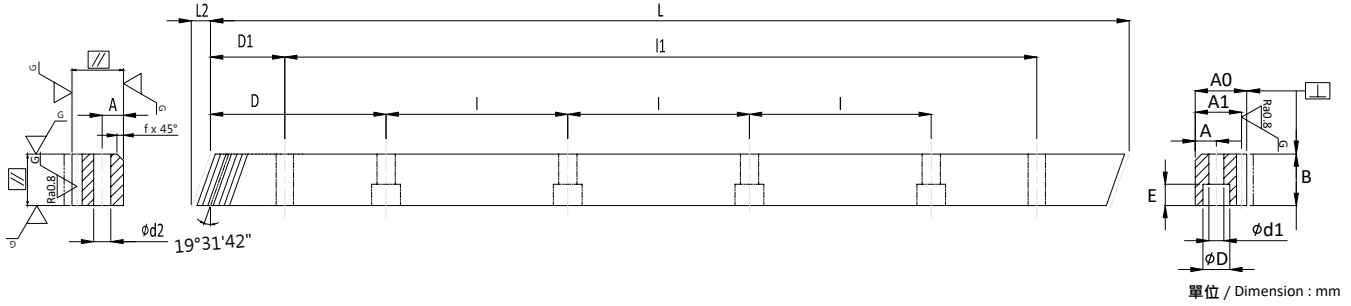

系列 CHTGH-DIN6 斜齒齒研齒條
品質等級 DIN 6

材料 S45C
右旋角 19°31'42"
硬度 HRC 50~55°
硬化處理後四面研磨與齒研
總齒距誤差: $F_p/1000 \leq 0.036 \text{ mm}$
 $F_p/2000 \leq 0.047 \text{ mm} (\leq 0.024/1000 \text{ mm})$

Series CHTGH-DIN6 Helical Teeth Ground Racks
Quality Grade DIN 6

Material S45C
Right Hand Angle 19°31'42"
Hardness HRC 50~55°
Ground on all sides after hardening.
Total Pitch Error: $F_p/1000 \leq 0.036 \text{ mm}$
 $F_p/2000 \leq 0.047 \text{ mm} (\leq 0.024/1000 \text{ mm})$

型號 Code	模數 Module	L	L2	齒數 No. of Teeth	B	A0	A1	D	l	孔數 No. of Holes	A	φd1	φD	E	D1	l1	φd2	f	F _{ta} kN	KG
CHTGH01505-DIN6	1.5	500.00	6.70	100	19	19	17.5	62.5	125	4	8	7	11	7	31.7	436.60	5.7	1.5	6.87	1.3
CHTGH01510-DIN6	1.5	1000.00	6.70	200	19	19	17.5	62.5	125	8	8	7	11	7	31.7	936.60	5.7	1.5	6.97	2.6
CHTGH02005-DIN6	2	500.00	8.50	75	24	24	22.0	62.5	125	4	8	7	11	7	31.7	436.60	5.7	2	11.46	2.1
CHTGH02010-DIN6	2	1000.00	8.50	150	24	24	22.0	62.5	125	8	8	7	11	7	31.7	936.60	5.7	2	11.68	4.1
CHTGH02020-DIN6	2	2000.00	8.50	300	24	24	22.0	62.5	125	16	8	7	11	7	31.7	1936.60	5.7	2	11.80	8.2
CHTGH02505-DIN6	2.5	500.00	8.50	60	24	24	21.5	62.5	125	4	9	7	11	7	31.7	436.60	5.7	2	14.20	2.1
CHTGH02510-DIN6	2.5	1000.00	8.50	120	24	24	21.5	62.5	125	8	9	7	11	7	31.7	936.60	5.7	2	14.52	4.1
CHTGH02520-DIN6	2.5	2000.00	8.50	240	24	24	21.5	62.5	125	16	9	7	11	7	31.7	1936.60	5.7	2	14.71	8.2
CHTGH03005-DIN6	3	500.00	10.30	50	29	29	26.0	62.5	125	4	9	10	15	9	35.0	430.00	7.7	2	20.41	3.0
CHTGH03010-DIN6	3	1000.00	10.30	100	29	29	26.0	62.5	125	8	9	10	15	9	35.0	930.00	7.7	2	20.96	6.0
CHTGH03020-DIN6	3	2000.00	10.30	200	29	29	26.0	62.5	125	16	9	10	15	9	35.0	1930.00	7.7	2	21.28	12.0
CHTGH04005-DIN6	4	506.67	13.80	38	39	39	35.0	62.5	125	4	12	10	15	9	33.3	433.00	7.7	2	36.11	5.5
CHTGH04010-DIN6	4	1000.00	13.80	75	39	39	35.0	62.5	125	8	12	10	15	9	33.3	933.40	7.7	2	37.24	10.8
CHTGH04020-DIN6	4	2000.00	13.80	150	39	39	35.0	62.5	125	16	12	10	15	9	33.3	1933.40	7.7	2	37.95	21.6
CHTGH05005-DIN6	5	500.00	17.40	30	49	49	34.0	62.5	125	4	12	14	20	13	37.5	425.00	11.7	3	55.95	6.8
CHTGH05010-DIN6	5	1000.00	17.40	60	49	49	34.0	62.5	125	8	12	14	20	13	37.5	925.00	11.7	3	57.97	13.6
CHTGH05020-DIN6	5	2000.00	17.40	120	49	49	34.0	62.5	125	16	12	14	20	13	37.5	1925.00	11.7	3	59.30	27.2
CHTGH06005-DIN6	6	500.00	20.90	25	59	59	43.0	62.5	125	4	16	18	26	17	37.5	425.00	15.7	3	79.91	10.3
CHTGH06010-DIN6	6	1000.00	20.90	50	59	59	43.0	62.5	125	8	16	18	26	17	37.5	925.00	15.7	3	83.07	20.5
CHTGH06020-DIN6	6	2000.00	20.90	100	59	59	43.0	62.5	125	16	16	18	26	17	37.5	1925.00	15.7	3	85.29	41.1
CHTGH08005-DIN6	8	480.00	28.00	18	79	79	71.0	60.0	120	4	25	22	33	21	120.0	240.00	19.7	4	139.40	21.3
CHTGH08010-DIN6	8	960.00	28.00	36	79	79	71.0	60.0	120	8	25	22	33	21	120.0	720.00	19.7	4	145.83	42.6
CHTGH08020-DIN6	8	1920.00	28.00	72	79	79	71.0	60.0	120	16	25	22	33	21	120.0	1680.00	19.7	4	150.59	85.1
CHTGH10005-DIN6	10	500.00	35.11	15	99	99	89.0	62.5	125	4	32	33	48	32	125.0	250.00	19.7	5	215.33	34.8
CHTGH10010-DIN6	10	1000.00	35.11	30	99	99	89.0	62.5	125	8	32	33	48	32	125.0	750.00	19.7	5	226.09	69.6



MHTG-DIN6

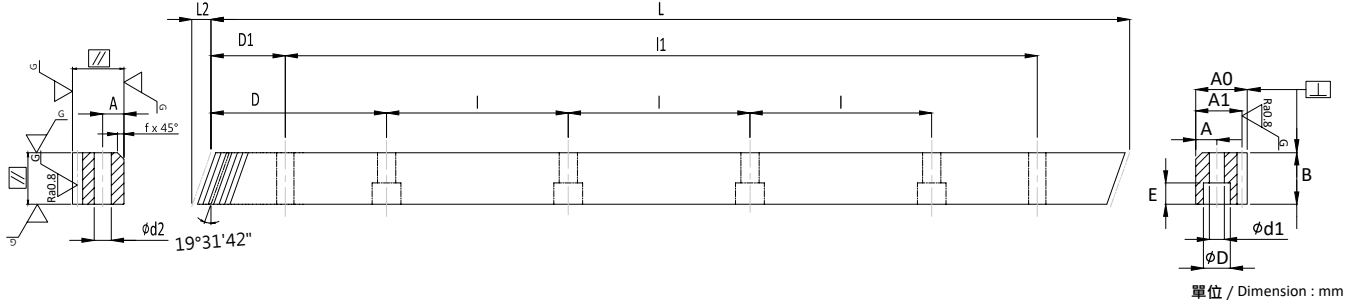

斜齒 Helical
DIN

系列 MHTG-DIN6 斜齒齒研齒條
品質等級 DIN 6

材料 SCM440
右旋角 19°31'42"
硬度 HRC 10~12°
四面研磨與齒研
總齒距誤差 : $F_p/1000 \leq 0.036 \text{ mm}$
 $F_p/2000 \leq 0.047 \text{ mm} (\leq 0.024/1000 \text{ mm})$

Series MHTG-DIN6 Helical Teeth Ground Racks
Quality Grade DIN 6

Material SCM440
Right Hand Angle 19°31'42"
Hardness HRC 10~12°
Ground on all sides.
Total Pitch Error: $F_p/1000 \leq 0.036 \text{ mm}$
 $F_p/2000 \leq 0.047 \text{ mm} (\leq 0.024/1000 \text{ mm})$

型號 Code	模數 Module	L	L2	齒數 No. of Teeth	B	A0	A1	D	l	孔數 No. of Holes	A	φd1	φD	E	D1	l1	φd2	f	F _{ta} kN	KG
MHTG01505-DIN6	1.5	500.00	6.70	100	19	19	17.5	62.5	125	4	8	7	11	7	31.7	436.60	5.7	1.5	9.48	1.3
MHTG01510-DIN6	1.5	1000.00	6.70	200	19	19	17.5	62.5	125	8	8	7	11	7	31.7	936.60	5.7	1.5	9.63	2.6
MHTG02005-DIN6	2	500.00	8.50	75	24	24	22.0	62.5	125	4	8	7	11	7	31.7	436.60	5.7	2	15.82	2.1
MHTG02010-DIN6	2	1000.00	8.50	150	24	24	22.0	62.5	125	8	8	7	11	7	31.7	936.60	5.7	2	16.13	4.1
MHTG02020-DIN6	2	2000.00	8.50	300	24	24	22.0	62.5	125	16	8	7	11	7	31.7	1936.60	5.7	2	16.31	8.2
MHTG02505-DIN6	2.5	500.00	8.50	60	24	24	21.5	62.5	125	4	9	7	11	7	31.7	436.60	5.7	2	19.61	2.1
MHTG02510-DIN6	2.5	1000.00	8.50	120	24	24	21.5	62.5	125	8	9	7	11	7	31.7	936.60	5.7	2	20.06	4.1
MHTG02520-DIN6	2.5	2000.00	8.50	240	24	24	21.5	62.5	125	16	9	7	11	7	31.7	1936.60	5.7	2	20.32	8.2
MHTG03005-DIN6	3	500.00	10.30	50	29	29	26.0	62.5	125	4	9	10	15	9	35.0	430.00	7.7	2	28.20	3.0
MHTG03010-DIN6	3	1000.00	10.30	100	29	29	26.0	62.5	125	8	9	10	15	9	35.0	930.00	7.7	2	28.95	6.0
MHTG03020-DIN6	3	2000.00	10.30	200	29	29	26.0	62.5	125	16	9	10	15	9	35.0	1930.00	7.7	2	29.39	12.0
MHTG04005-DIN6	4	506.67	13.80	38	39	39	35.0	62.5	125	4	12	10	15	9	33.3	433.00	7.7	2	49.87	5.5
MHTG04010-DIN6	4	1000.00	13.80	75	39	39	35.0	62.5	125	8	12	10	15	9	33.3	933.40	7.7	2	51.43	10.8
MHTG04020-DIN6	4	2000.00	13.80	150	39	39	35.0	62.5	125	16	12	10	15	9	33.3	1933.40	7.7	2	52.42	21.6
MHTG05005-DIN6	5	500.00	17.40	30	49	49	34.0	62.5	125	4	12	14	20	13	37.5	425.00	11.7	3	77.28	6.8
MHTG05010-DIN6	5	1000.00	17.40	60	49	49	34.0	62.5	125	8	12	14	20	13	37.5	925.00	11.7	3	80.06	13.6
MHTG05020-DIN6	5	2000.00	17.40	120	49	49	34.0	62.5	125	16	12	14	20	13	37.5	1925.00	11.7	3	81.90	27.2
MHTG06005-DIN6	6	500.00	20.90	25	59	59	43.0	62.5	125	4	16	18	26	17	37.5	425.00	15.7	3	110.37	10.3
MHTG06010-DIN6	6	1000.00	20.90	50	59	59	43.0	62.5	125	8	16	18	26	17	37.5	925.00	15.7	3	114.73	20.5
MHTG06020-DIN6	6	2000.00	20.90	100	59	59	43.0	62.5	125	16	16	18	26	17	37.5	1925.00	15.7	3	117.80	41.1
MHTG08005-DIN6	8	480.00	28.00	18	79	79	71.0	60.0	120	4	25	22	33	21	120.0	240.00	19.7	4	192.53	21.3
MHTG08010-DIN6	8	960.00	28.00	36	79	79	71.0	60.0	120	8	25	22	33	21	120.0	720.00	19.7	4	201.42	42.6
MHTG08020-DIN6	8	1920.00	28.00	72	79	79	71.0	60.0	120	16	25	22	33	21	120.0	1680.00	19.7	4	207.99	85.1

CHTM-DIN8

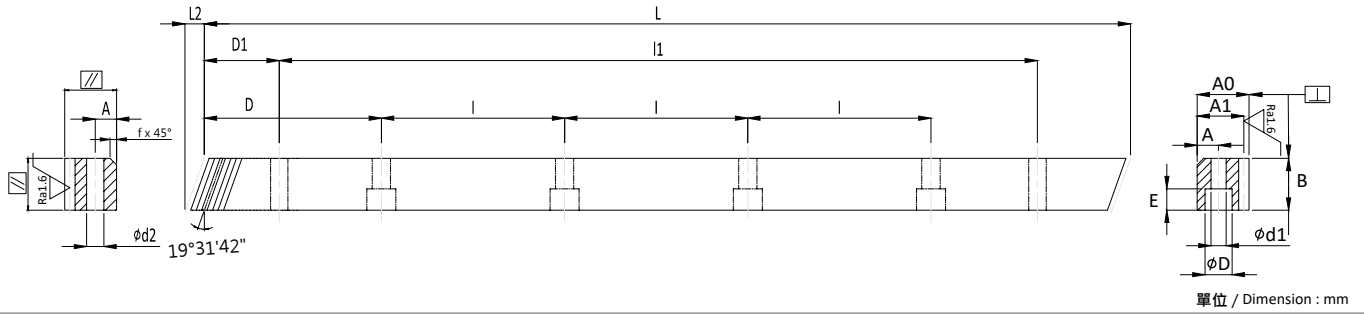

系列 CHTM-DIN8 斜齒精銑齒條
品質等級 DIN 8

材料 S45C
右旋角 19°31'42"
硬度 HRC 10~12°
總齒距誤差 : $F_p / 1000 \leq 0.060 \text{ mm}$
 $F_p / 2000 \leq 0.080 \text{ mm}$

Series CHTM-DIN8 Helical Milled Racks
Quality Grade DIN 8

Material S45C
Right Hand Angle 19°31'42"
Hardness: HRC 10~12°
Total Pitch Error: $F_p / 1000 \leq 0.060 \text{ mm}$
 $F_p / 2000 \leq 0.080 \text{ mm}$

型號 Code	模數 Module	L	L2	齒數 No. of Teeth	B	A0	A1	D	I	孔數 No. of Holes	A	ød1	øD	E	D1	I1	ød2	f	F _{ta} kN	KG
CHTM01510-DIN8	1.5	1000	6.00	200	17	17	15.5	62.5	125	8	7	6	9.5	6	31.7	936.6	5.70	1.5	4.35	2.1
CHTM02010-DIN8	2	1000	8.90	150	25	24	22	62.5	125	8	8	7	11	7	31.7	936.6	5.70	2	8.49	4.3
CHTM02020-DIN8	2	2000	8.90	300	25	24	22	62.5	125	16	8	7	11	7	31.7	1936.6	5.70	2	8.58	8.5
CHTM03010-DIN8	3	1000	10.60	100	30	29	26	62.5	125	8	9	10	15	9	35.0	930.0	7.70	2	15.13	6.2
CHTM03020-DIN8	3	2000	10.60	200	30	29	26	62.5	125	16	9	10	15	9	35.0	1930.0	7.70	2	15.36	12.4
CHTM04010-DIN8	4	1000	14.20	75	40	39	35	62.5	125	8	12	10	15	9	33.3	933.4	7.70	2	26.65	11.1
CHTM04020-DIN8	4	2000	14.20	150	40	39	35	62.5	125	16	12	10	15	9	33.3	1933.4	7.70	2	27.16	22.2
CHTM05010-DIN8	5	1000	17.40	60	49	39	34	62.5	125	8	12	14	20	13	37.5	925.0	11.70	3	40.44	13.6
CHTM05020-DIN8	5	2000	17.40	120	49	39	34	62.5	125	16	12	14	20	13	37.5	1925.0	11.70	3	41.37	27.2
CHTM06010-DIN8	6	1000	20.90	50	59	49	43	62.5	125	8	16	18	26	17	37.5	925.0	15.70	3	57.96	20.5
CHTM06020-DIN8	6	2000	20.90	100	59	49	43	62.5	125	16	16	18	26	17	37.5	1925.0	15.70	3	59.51	41.1
CHTM08010-DIN8	8	960	28.00	36	79	79	71	60	120	8	25	22	33	21	120.0	720.0	19.70	4	101.75	42.6
CHTM08020-DIN8	8	1920	28.00	72	79	79	71	60	120	16	25	22	33	21	120.0	1680.0	19.70	4	105.07	85.1
CHTM10010-DIN8	10	1000	35.11	30	99	99	89	62.5	125	8	32	33	48	32	125.0	750.0	19.70	5	157.75	69.6

※ 重量僅供參考，實重須經實秤為準。

※ Weight only for reference. Actual scale should be Weighing.

CHTMQ-DIN8

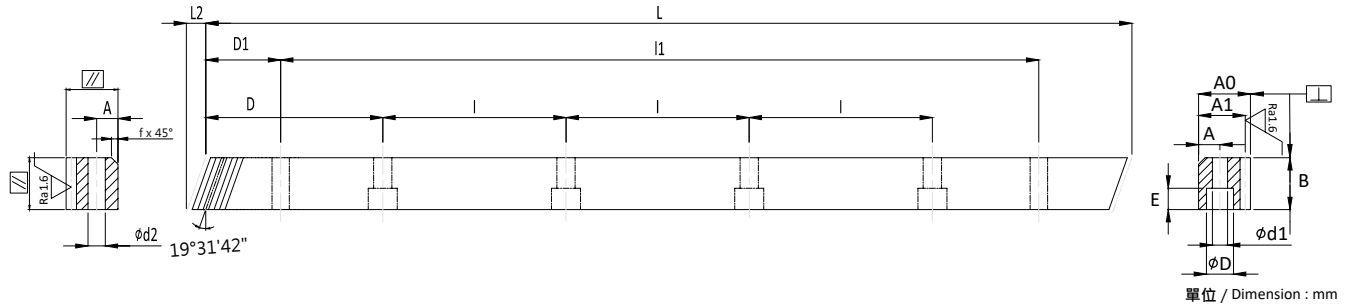

斜齒 Helical
DIN

系列 CHTMQ-DIN8 斜齒精銑調質齒條
品質等級 DIN 8

Series CHTMQ-DIN8 Helical Milled Quenched & Tempered Racks
Quality Grade DIN 8

材料 S45C
右旋角 19°31'42"
硬度 HRC 18~22°
總齒距誤差 : $F_p / 1000 \leq 0.060 \text{ mm}$
 $F_p / 2000 \leq 0.080 \text{ mm}$

Material S45C
Right Hand Angle 19°31'42"
Hardness: HRC 18~22°
Total Pitch Error: $F_p / 1000 \leq 0.060 \text{ mm}$
 $F_p / 2000 \leq 0.080 \text{ mm}$

型號 Code	模數 Module	L	L2	齒數 No. of Teeth	B	A0	A1	D	I	孔數 No. of Holes	A	ød1	øD	E	D1	I1	ød2	f	F _{ta} kN	KG
CHTMQ01510-DIN8	1.5	1000	6.00	200	17	17	15.5	62.5	125	8	7	6	9.5	7	31.7	936.6	5.7	1.5	5.28	2.1
CHTMQ02010-DIN8	2	1000	8.90	150	25	24	22	62.5	125	8	8	7	11	7	31.7	936.6	5.7	2	10.29	4.3
CHTMQ02020-DIN8	2	2000	8.90	300	25	24	22	62.5	125	16	8	7	11	7	31.7	1936.6	5.7	2	10.41	8.5
CHTMQ03010-DIN8	3	1000	10.60	100	30	29	26	62.5	125	8	9	10	15	9	35.0	930.0	7.7	2	18.35	6.2
CHTMQ03020-DIN8	3	2000	10.60	200	30	29	26	62.5	125	16	9	10	15	9	35.0	1930.0	7.7	2	18.62	12.4
CHTMQ04010-DIN8	4	1000	14.20	75	40	39	35	62.5	125	8	12	10	15	9	33.3	933.4	7.7	2	32.32	11.1
CHTMQ04020-DIN8	4	2000	14.20	150	40	39	35	62.5	125	16	12	10	15	9	33.3	1933.4	7.7	2	32.94	22.2
CHTMQ05010-DIN8	5	1000	17.40	60	49	39	34	62.5	125	8	12	14	20	13	37.5	925.0	11.7	3	49.05	13.6
CHTMQ05020-DIN8	5	2000	17.40	120	49	39	34	62.5	125	16	12	14	20	13	37.5	1925.0	11.7	3	50.18	27.2
CHTMQ06010-DIN8	6	1000	20.90	50	59	49	43	62.5	125	8	16	18	26	17	37.5	925.0	15.7	3	70.29	20.5
CHTMQ06020-DIN8	6	2000	20.90	100	59	49	43	62.5	125	16	16	18	26	17	37.5	1925.0	15.7	3	72.17	41.1
CHTMQ08010-DIN8	8	960	28.00	36	79	79	71	60	120	8	25	22	33	21	120.0	720.0	19.7	4	123.40	42.6
CHTMQ08020-DIN8	8	1920	28.00	18	79	79	71	60	120	16	25	22	33	21	120.0	1680.0	19.7	4	117.95	85.1
CHTMQ10010-DIN8	10	1000	35.11	30	99	99	89	62.5	125	8	32	33	48	32	125.0	750.0	19.7	5	191.31	69.6

※ 重量僅供參考，實重須經實秤為準。

※ Weight only for reference. Actual scale should be Weighing.

CHTMH-DIN10

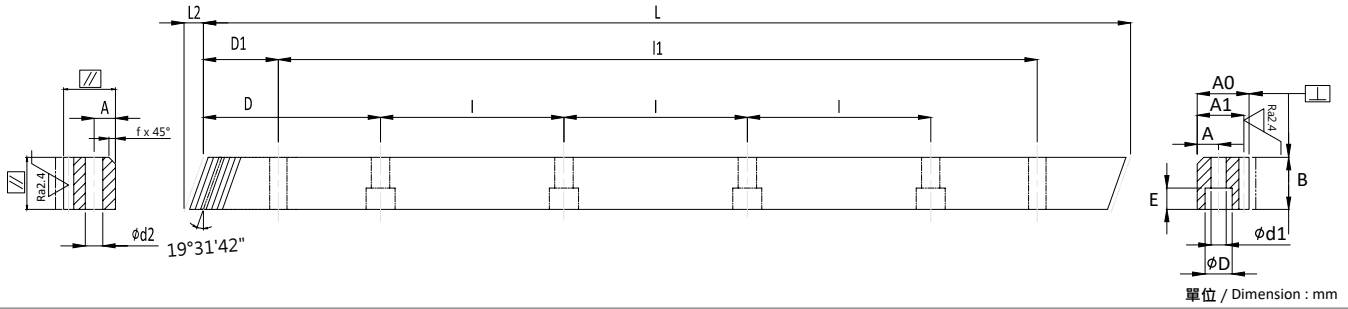

系列 CHTMH-DIN10 斜齒熱處理齒條
品質等級 DIN 10

材料 S45C
右旋角 19°31'42"
硬度 HRC 50~55°
表面 噴砂處理
總齒距誤差 : $F_p / 1000 \leq 0.15 \text{ mm}$

Series CHTMH-DIN 10 Helical Hardened Racks
Quality Grade DIN 10

Material S45C
Right Hand Angle 19°31'42"
Hardness: HRC 50~55°
Surfaces: Sand-blasted.
Total Pitch Error: $F_p / 1000 \leq 0.15 \text{ mm}$

型號 Code	模數 Module	L	L2	齒數 No. of Teeth	B	A0	A1	D	l	孔數 No. of Holes	A	ød1	øD	E	D1	l1	ød2	f	F _{ta} kN	KG
CHTMH01510-DIN10	1.5	1000	6.00	200	17	17	15.5	62.5	125	8	7	6	9.5	7	31.7	936.6	5.7	1.5	4.57	2.1
CHTMH02010-DIN10	2	1000	8.50	150	24	24	22	62.5	125	8	8	7	11	7	31.7	936.6	5.7	2	8.56	4.1
CHTMH02020-DIN10	2	2000	8.50	300	24	24	22	62.5	125	16	8	7	11	7	31.7	1936.6	5.7	2	8.66	8.2
CHTMH03010-DIN10	3	1000	10.30	100	29	29	26	62.5	125	8	9	10	15	9	35.0	930.0	7.7	2	15.37	6.0
CHTMH03020-DIN10	3	2000	10.30	200	29	29	26	62.5	125	16	9	10	15	9	35.0	1930.0	7.7	2	15.60	12.0
CHTMH04010-DIN10	4	1000	13.80	75	39	39	35	62.5	125	8	12	10	15	9	33.3	933.4	7.7	2	27.31	10.8
CHTMH04020-DIN10	4	2000	13.80	150	39	39	35	62.5	125	16	12	10	15	9	33.3	1933.4	7.7	2	27.83	21.6
CHTMH05010-DIN10	5	1000	17.40	60	49	39	34	62.5	125	8	12	14	20	13	37.5	925.0	11.7	3	42.51	13.6
CHTMH05020-DIN10	5	2000	17.40	120	49	39	34	62.5	125	16	12	14	20	13	37.5	1925.0	11.7	3	43.49	27.2
CHTMH06010-DIN10	6	1000	20.90	50	59	49	43	62.5	125	8	16	18	26	17	37.5	925.0	15.7	3	60.92	20.5
CHTMH06020-DIN10	6	2000	20.90	100	59	49	43	62.5	125	16	16	18	26	17	37.5	1925.0	15.7	3	62.54	41.1
CHTMH08010-DIN10	8	960	28.00	36	79	79	71	60	120	8	25	22	33	21	120.0	720.0	19.7	4	106.94	42.6
CHTMH08020-DIN10	8	1920	28.00	72	79	79	71	60	120	16	25	22	33	21	120.0	1680.0	19.7	4	110.43	85.1
CHTMH10010-DIN10	10	1000	35.11	30	99	99	89	62.5	125	8	32	33	48	32	125.0	750.0	19.7	5	165.80	69.6

CSTGH-DIN5

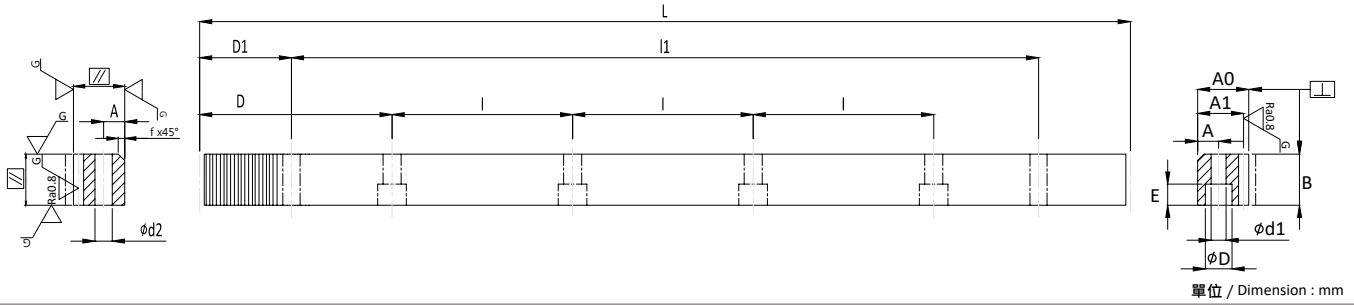

單位 / Dimension : mm

系列 CSTGH-DIN5 直齒齒研齒條
品質等級 DIN 5

Series CSTGH-DIN5 Straight Teeth Ground Racks
Quality Grade DIN 5

材料 S45C
硬度 HRC 50~55°
硬化處理後四面研磨與齒研
總齒距誤差 : $F_p / 1000 \leq 0.026$ mm
室溫在攝氏 25° 為準

Material S45C
Hardness: HRC 50~55°
Ground on all sides after hardening.
Total Pitch Error: $F_p / 1000 \leq 0.026$ mm
Room Temperature is 25°C

型號 Code	模數 Module	L	齒數 No. of Teeth	B	A0	A1	D	l	孔數 No. of Holes	A	ød1	øD	E	D1	l1	ød2	f	F _{ta} kN	KG
CSTGH02010-DIN5	2	1005.31	160	24	24	22	62.83	125.66	8	8	7	11	7	31.3	942.70	5.7	2	9.73	4.1
CSTGH03010-DIN5	3	1017.88	108	29	29	26	63.61	127.23	8	9	10	11	9	34.4	949.10	7.7	2	17.48	6.1
CSTGH04010-DIN5	4	1005.31	80	39	39	35	62.83	125.66	8	12	10	15	9	37.5	930.30	7.7	2	31.04	10.9
CSTGH05010-DIN5	5	1005.31	64	49	39	34	62.83	125.66	8	12	14	17	13	37.5	945.00	11.7	3	48.37	17.2

直齒 Straight
DIN

CSTGH-DIN6

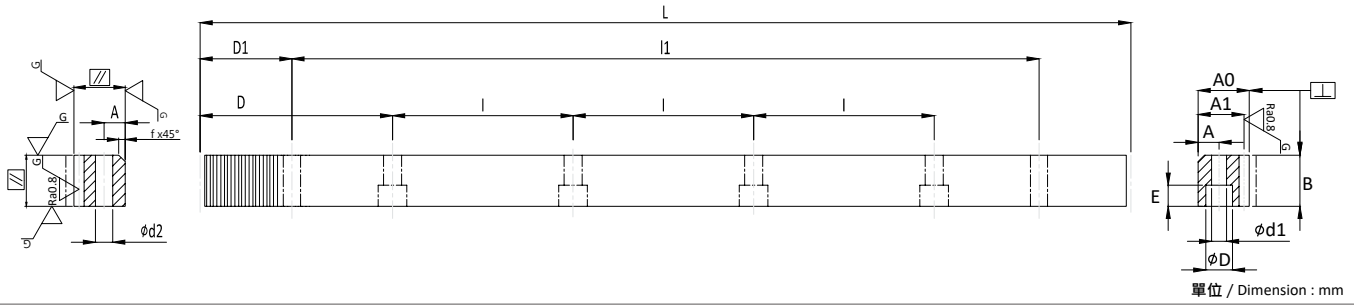

系列 CSTGH-DIN6 直齒齒研齒條
品質等級 DIN 6

Series CSTGH-DIN6 Straight Teeth Ground Racks
Quality Grade DIN 6

材料 S45C
硬度 HRC 50~55°
硬化處理後四面研磨與齒研
總齒距誤差：Fp /1000 ≤ 0.036 mm
Fp /2000 ≤ 0.047 mm (≤ 0.024/1000 mm)

Material S45C
Hardness: HRC 50~55°
Ground on all sides after hardening.
Total Pitch Error: Fp /1000 ≤ 0.036 mm
Fp /2000 ≤ 0.047 mm (≤ 0.024/1000 mm)

型號 Code	模數 Module	L	齒數 No. of Teeth	B	A0	A1	D	l	孔數 No. of Holes	A	ød1	øD	E	D1	l1	ød2	f	F _{ta} kN	KG
CSTGH01505-DIN6	1.5	499.51	106	19	19	17.5	62.44	124.88	4	8	6	9.5	7	29.0	441.50	5.7	1.5	5.72	1.3
CSTGH01510-DIN6	1.5	999.03	212	19	19	17.5	62.44	124.88	8	8	6	9.5	7	29.0	941.00	5.7	1.5	5.81	2.6
CSTGH02005-DIN6	2	502.65	80	24	24	22	62.83	125.66	4	8	7	11	7	31.3	440.10	5.7	2	9.55	2.1
CSTGH02010-DIN6	2	1005.31	160	24	24	22	62.83	125.66	8	8	7	11	7	31.3	942.70	5.7	2	9.73	4.1
CSTGH02020-DIN6	2	2010.62	320	24	24	22	62.83	125.66	16	8	7	11	7	31.3	1948.00	5.7	2	9.83	8.2
CSTGH02505-DIN6	2.5	502.65	64	24	24	21.5	62.83	125.66	4	9	7	11	7	31.3	440.10	5.7	2	11.85	2.1
CSTGH02510-DIN6	2.5	1005.31	128	24	24	21.5	62.83	125.66	8	9	7	11	7	31.3	942.70	5.7	2	12.10	4.1
CSTGH02520-DIN6	2.5	2010.62	256	24	24	21.5	62.83	125.66	16	9	7	11	7	31.3	1948.00	5.7	2	12.25	8.2
CSTGH03005-DIN6	3	508.94	54	29	29	26	63.62	127.23	4	9	10	15	9	34.4	440.10	7.7	2	17.05	3.0
CSTGH03010-DIN6	3	1017.88	108	29	29	26	63.62	127.23	8	9	10	15	9	34.4	949.10	7.7	2	17.48	6.1
CSTGH03020-DIN6	3	2035.75	216	29	29	26	63.62	127.23	16	9	10	15	9	34.4	1967.00	7.7	2	17.73	12.2
CSTGH04005-DIN6	4	502.65	40	39	39	35	62.83	125.66	4	12	10	15	9	37.5	427.70	7.7	2	30.13	5.4
CSTGH04010-DIN6	4	1005.31	80	39	39	35	62.83	125.66	8	12	10	15	9	37.5	930.30	7.7	2	31.04	10.9
CSTGH04020-DIN6	4	2010.62	160	39	39	35	62.83	125.66	16	12	10	15	9	37.5	1935.60	7.7	2	31.63	21.7
CSTGH05005-DIN6	5	502.65	32	49	49	34	62.83	125.66	4	12	14	20	13	30.1	442.30	11.7	3	46.73	6.8
CSTGH05010-DIN6	5	1005.31	64	49	49	34	62.83	125.66	8	12	14	20	13	30.1	945.00	11.7	3	48.37	13.7
CSTGH05020-DIN6	5	2010.62	128	49	49	34	62.83	125.66	16	12	14	20	13	30.1	1950.40	11.7	3	49.42	27.3
CSTGH06005-DIN6	6	508.94	27	59	59	43	63.62	127.23	4	16	18	26	17	31.4	446.10	15.7	3	66.82	10.5
CSTGH06010-DIN6	6	1017.88	54	59	59	43	63.62	127.23	8	16	18	26	17	31.4	955.00	15.7	3	69.37	20.9
CSTGH06020-DIN6	6	2035.75	108	59	59	43	63.62	127.23	16	16	18	26	17	31.4	1973.00	15.7	3	71.11	41.8
CSTGH08005-DIN6	8	502.65	20	79	79	71	62.83	125.66	4	25	22	33	21	26.6	449.45	19.7	4	116.91	22.3
CSTGH08005-DIN6	8	1005.31	40	79	79	71	62.83	125.66	8	25	22	33	21	26.6	952.00	19.7	4	122.06	44.6
CSTGH08020-DIN6	8	2010.61	80	79	79	71	62.83	125.66	16	25	22	33	21	26.6	1957.40	19.7	4	125.76	89.1

齒研齒條
Straight
DIN

CSTM-DIN8

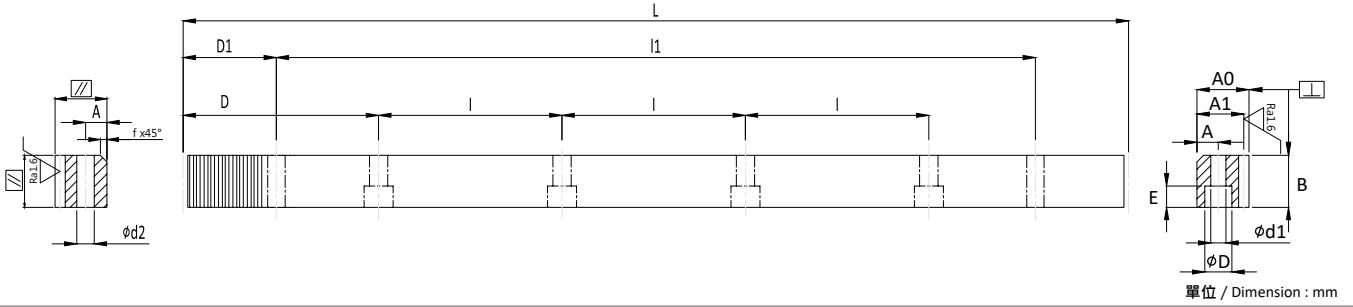

單位 / Dimension : mm

系列 CSTM-DIN8 直齒精銑齒條
品質等級 DIN 8

Series CSTM-DIN8 Straight Milled Racks
Quality Grade DIN 8

材料 S45C
硬度 HRC 10~12°
總齒距誤差 : $F_p / 1000 \leq 0.060$ mm
 $F_p / 2000 \leq 0.080$ mm

Material S45C
Hardness: HRC 10~12°
Total Pitch Error: $F_p / 1000 \leq 0.060$ mm
 $F_p / 2000 \leq 0.080$ mm

型號 Code	模數 Module	L	齒數 No. of Teeth	B	A0	A1	D	I	孔數 No. of Holes	A	φd1	φD	E	D1	l1	φd2	f	F _{ta} kN	KG
CSTM01510-DIN8	1.5	999.03	212	17	17	15.5	62.44	124.88	8	7	6	9.5	7	29	941.00	5.7	1.5	3.62	1.9
CSTM02010-DIN8	2	1005.31	160	25	24	22	62.83	125.66	8	8	7	11	7	31.3	942.70	5.7	2	7.07	4.1
CSTM02020-DIN8	2	2010.62	320	25	24	22	62.83	125.66	16	8	7	11	7	31.3	1948.00	5.7	2	7.15	8.1
CSTM03010-DIN8	3	1017.88	108	30	29	26	63.62	127.23	8	9	10	15	9	34.4	949.10	7.7	2	12.61	5.9
CSTM03020-DIN8	3	2035.75	216	30	29	26	63.62	127.23	16	9	10	15	9	34.4	1967.00	7.7	2	12.80	11.9
CSTM04010-DIN8	4	1005.31	80	40	39	35	62.83	125.66	8	12	10	15	9	37.5	930.30	7.7	2	22.21	10.5
CSTM04020-DIN8	4	2010.62	160	40	39	35	62.83	125.66	16	12	10	15	9	37.5	1935.60	7.7	2	22.63	21.0
CSTM05010-DIN8	5	1005.31	64	49	39	34	62.83	125.66	8	12	14	20	13	30.1	945.00	11.7	3	33.75	12.9
CSTM05020-DIN8	5	2010.62	128	49	39	34	62.83	125.66	16	12	14	20	13	30.1	1950.40	11.7	3	34.48	25.8
CSTM06010-DIN8	6	1017.88	54	59	49	43	63.62	127.23	8	16	18	26	17	31.4	955.00	15.7	3	48.40	19.7
CSTM06020-DIN8	6	2035.75	108	59	49	43	63.62	127.23	16	16	18	26	17	31.4	1973.00	15.7	3	49.61	39.5
CSTM08010-DIN8	8	1005.31	40	79	79	71	62.83	125.66	8	25	22	33	21	26.6	952.00	19.7	4	85.17	42.1
CSTM08020-DIN8	8	2010.61	80	79	79	71	62.83	125.66	16	25	22	33	21	26.6	1957.40	19.7	4	87.75	84.2
CSTM10010-DIN8	10	1005.31	32	99	99	89	62.83	125.66	8	32	33	48	32	125.67	754.00	19.7	5	131.75	66.1

※ 重量僅供參考，實重須經實秤為準。

※ Weight only for reference. Actual scale should be Weighing.

CSTMQ-DIN8

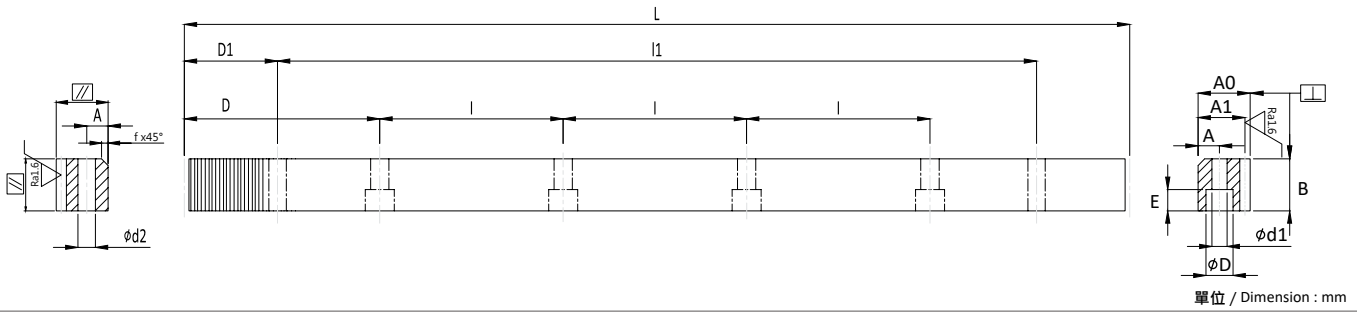

系列 CSTMQ-DIN8 直齒精銑調質齒條
品質等級 DIN 8

Series CSTMQ-DIN8 Straight Milled Quenched & Tempered Racks
Quality Grade DIN 8

材料 S45C
硬度 HRC 18~22°
總齒距誤差： $F_p / 1000 \leq 0.060 \text{ mm}$
 $F_p / 2000 \leq 0.080 \text{ mm}$

Material S45C
Hardness: HRC 18~22°
Total Pitch Error: $F_p / 1000 \leq 0.060 \text{ mm}$
 $F_p / 2000 \leq 0.080 \text{ mm}$

型號 Code	模數 Module	L	齒數 No. of Teeth	B	A0	A1	D	l	孔數 No. of Holes	A	φd1	φD	E	D1	l1	φd2	f	F _{ta} kN	KG
CSTMQ01510-DIN8	1.5	999.03	212	17	17	15.5	62.44	124.88	8	7	6	9.5	7	29	941.00	5.7	1.5	4.40	1.9
CSTMQ02010-DIN8	2	1005.31	160	25	24	22	62.83	125.66	8	8	7	11	7	31.3	942.70	5.7	2	8.58	4.1
CSTMQ02020-DIN8	2	2010.62	320	25	24	22	62.83	125.66	16	8	7	11	7	31.3	1948.00	5.7	2	8.67	8.1
CSTMQ03010-DIN8	3	1017.88	108	30	29	26	63.62	127.23	8	9	10	15	9	34.4	949.10	7.7	2	15.30	5.9
CSTMQ03020-DIN8	3	2035.75	216	30	29	26	63.62	127.23	16	9	10	15	9	34.4	1967.00	7.7	2	15.52	11.9
CSTMQ04010-DIN8	4	1005.31	80	40	39	35	62.83	125.66	8	12	10	15	9	37.5	930.30	7.7	2	26.94	10.5
CSTMQ04020-DIN8	4	2010.62	160	40	39	35	62.83	125.66	16	12	10	15	9	37.5	1935.60	7.7	2	27.45	21.0
CSTMQ05010-DIN8	5	1005.31	64	49	39	34	62.83	125.66	8	12	14	20	13	30.1	945.00	11.7	3	40.93	12.9
CSTMQ05020-DIN8	5	2010.62	128	49	39	34	62.83	125.66	16	12	14	20	13	30.1	1950.40	11.7	3	41.82	25.8
CSTMQ06010-DIN8	6	1017.88	54	59	49	43	63.62	127.23	8	16	18	26	17	31.4	955.00	15.7	3	58.70	19.7
CSTMQ06020-DIN8	6	2035.75	108	59	49	43	63.62	127.23	16	16	18	26	17	31.4	1973.00	15.7	3	60.17	39.5
CSTMQ08010-DIN8	8	1005.31	40	79	79	71	62.83	125.66	8	25	22	33	21	26.6	952.00	19.7	4	103.28	42.1
CSTMQ08020-DIN8	8	2010.61	80	79	79	71	62.83	125.66	16	25	22	33	21	26.6	1957.30	19.7	4	106.42	84.2
CSTMQ10010-DIN8	10	1005.31	32	99	99	89	62.83	125.66	8	32	33	48	32	125.67	753.96	19.7	5	159.78	66.1

直齒 Straight
DIN

CSTMH-DIN10

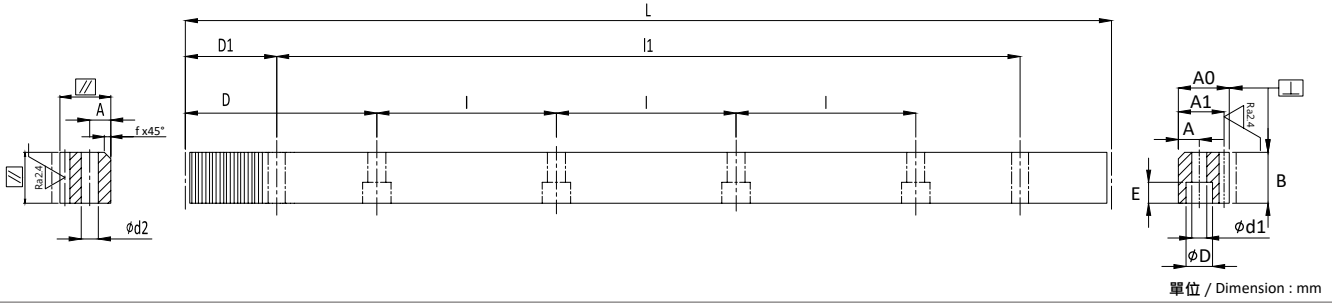

單位 / Dimension : mm

系列 CSTMH-DIN10 直齒硬化齒條
品質等級 DIN 10

Series CSTMH-DIN10 Straight Hardened Racks
Quality Grade DIN10

材料 S45C
硬度 HRC 50~55°
表面 噴砂或磷酸鹽處理
總齒距誤差 : $F_p / 1000 \leq 0.1 \text{ mm}$

Material S45C
Hardness: HRC 50~55°
Surfaces: Sand-blasted or phosphated.
Total Pitch Error: $F_p / 1000 \leq 0.1 \text{ mm}$

型號 Code	模數 Module	L	齒數 No. of Teeth	B	A0	A1	D	I	孔數 No. of Holes	A	ød1	øD	E	D1	l1	ød2	f	F _{ta} kN	KG
CSTMH01510-DIN10	1.5	999.03	212	17	17	15.5	62.44	124.88	8	7	6	9.5	7	29	941.00	5.7	1.5	3.81	1.9
CSTMH02010-DIN10	2	1005.31	160	24	24	22	62.83	125.66	8	8	7	11	7	31.3	942.70	5.7	2	7.14	3.9
CSTMH02020-DIN10	2	2010.62	320	24	24	22	62.83	125.66	16	8	7	11	7	31.3	1948.00	5.7	2	7.21	7.8
CSTMH03010-DIN10	3	1017.88	108	29	29	26	63.62	127.23	8	9	10	15	9	34.4	949.10	7.7	2	12.82	5.8
CSTMH03020-DIN10	3	2035.75	216	29	29	26	63.62	127.23	16	9	10	15	9	34.4	1967.00	7.7	2	13.00	11.5
CSTMH04010-DIN10	4	1005.31	80	39	39	35	62.83	125.66	8	12	10	15	9	37.5	930.30	7.7	2	22.76	10.3
CSTMH04020-DIN10	4	2010.62	160	39	39	35	62.83	125.66	16	12	10	15	9	37.5	1935.60	7.7	2	23.20	20.5
CSTMH05010-DIN10	5	1005.31	64	49	49	34	62.83	125.66	8	12	14	20	13	30.1	945.00	11.7	3	35.47	12.9
CSTMH05020-DIN10	5	2010.62	128	49	49	34	62.83	125.66	16	12	14	20	13	30.1	1950.30	11.7	3	50.84	25.8
CSTMH06010-DIN10	6	1017.88	54	59	59	43	63.62	127.23	8	16	18	26	17	31.4	955.00	15.7	3	50.87	19.7
CSTMH06020-DIN10	6	2035.75	108	59	59	43	63.62	127.23	16	16	18	26	17	31.4	1973.00	15.7	3	52.15	39.5
CSTMH08010-DIN10	8	1005.31	40	79	79	71	62.83	125.66	8	25	22	33	21	26.6	952.00	19.7	4	89.51	42.1
CSTMH10010-DIN10	10	1005.31	32	99	99	89	62.83	125.66	8	32	33	48	32	125.7	753.96	19.7	4	138.47	66.1

MHTGQ-JIS1

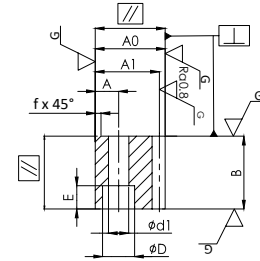
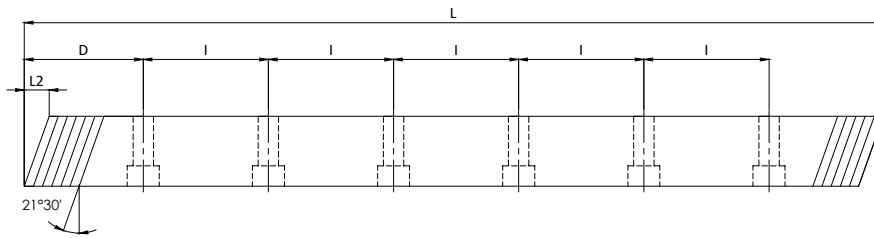

單位 / Dimension : mm

系列 MHTGQ-JIS1 斜齒調質齒研齒條
品質等級 JIS 1

材料 SCM440
右旋角 21°30'
硬度 HRC 18~22°
總齒距誤差 : $F_p/1000 \leq 0.033\text{mm}$
調質處理後四面研磨與齒研
無鑽孔處理 · 品號為 -N

Series MHTGQ-JIS1 Helical Quenched & Tempered Ground Racks
Quality Grade JIS 1

Material SCM440
Right Hand Angle 21°30'
Hardness: HRC 18~22°
Total Pitch Error: $F_p/1000 \leq 0.033\text{mm}$
Ground on all sides after quenching.
No Mounted Holes , Code with-N

型號 Code	模數 Module	L	L2	齒數 No. of Teeth	B	A0	A1	D	I	孔數 No. of Holes	螺絲 Screw	A	ød1	øD	E	f	F _{ta} kN	KG
MHTGQ01010-JIS1	1	1002.75	3.38	296	8	15	14	52.95	180	4	M4	6	4.5	8	4.4	1.5	2.63	0.4
MHTGQ01010-JIS1-N	1	1002.75	3.38	296	8	15	14	*	*	*	*	*	*	*	*	1.5	2.63	0.4
MHTGQ01510-JIS1	1.5	1002.53	5.07	197	12	20	18.5	53.63	180	4	M5	8	6	10	6.0	1.5	5.86	0.9
MHTGQ01510-JIS1-N	1.5	1002.53	5.07	197	12	20	18.5	*	*	*	*	*	*	*	*	1.5	5.86	0.9
MHTGQ02010-JIS1	2	1005.74	6.30	148	16	25	23	56.47	180	6	M6	10	7	11	7.0	2	10.53	2.9
MHTGQ02010-JIS1-N	2	1005.74	6.30	148	16	25	23	*	*	*	*	*	*	*	*	2	10.53	2.9
MHTGQ02510-JIS1	2.5	1013.92	7.88	118	20	30	27.5	56.46	180	6	M8	12	9	14	8.6	2	16.37	4.3
MHTGQ02510-JIS1-N	2.5	1013.92	7.88	118	20	30	27.5	*	*	*	*	*	*	*	*	2	16.37	4.3
MHTGQ03010-JIS1	3	1002.48	9.85	99	25	35	32	56.7	180	6	M10	14	11	18	10.8	2	24.44	6.2
MHTGQ03010-JIS1-N	3	1002.48	9.85	99	25	35	32	*	*	*	*	*	*	*	*	2	24.44	6.2

※ 重量僅供參考 · 實重須經實秤為準。

※ Weight only for reference. Actual scale should be Weighing.

CHTM-JIS4

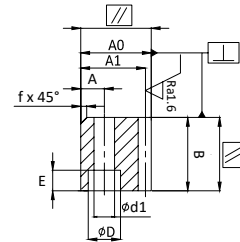
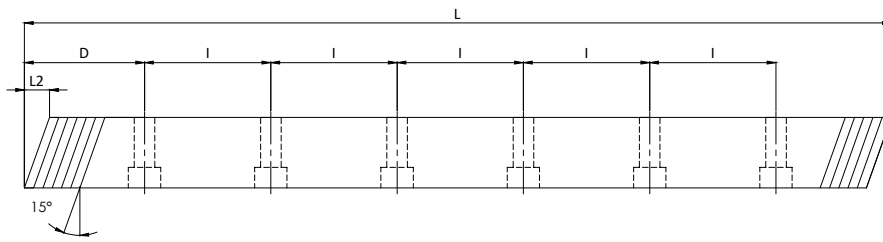

單位 / Dimension : mm

系列 CHTM-JIS4 斜齒齒條
品質等級 JIS 4

Series CHTM-JIS4 Helical Racks
Quality Grade JIS 4

材料 S45C
右旋角 15°
硬度 HRC 10~12°
表面 染黑處理
總齒距誤差 : $F_p/1000 \leq 0.075\text{mm}$
無鑽孔處理 · 品號為 -N

Material S45C
Right Hand Angle 15°
Hardness: HRC 10~12°
Surfaces: Black-coated
Total Pitch Error: $F_p/1000 \leq 0.075\text{mm}$
No Mounted Holes , Code with-N

型號 Code	模數 Module	L	L2	齒數 No. of Teeth	B	A0	A1	D	I	孔數 No. of Holes	螺絲 Screw	A	φd1	φD	E	f	F _{ta} kN	KG
CHTM02010-JIS4	2	1001.94	6.7	153	25	25	23	57	180	6	M6	10	7	11	7	2	8.86	4.5
CHTM02010-JIS4-N	2	1001.94	6.7	153	25	25	23	*	*	*	*	*	*	*	*	2	8.86	4.6
CHTM03010-JIS4	3	1004.62	9.38	102	35	35	32	57	180	6	M10	14	11	17.5	10.8	2	18.43	8.7
CHTM03010-JIS4-N	3	1004.62	9.38	102	35	35	32	*	*	*	*	*	*	*	*	2	18.43	8.8

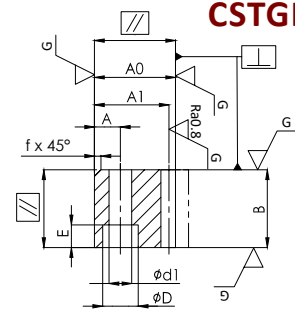
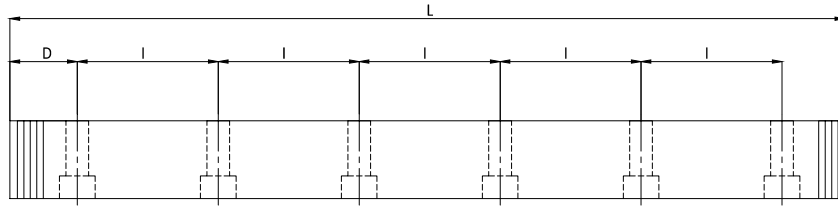

單位 / Dimension : mm

系列 CSTGH-JIS2 直齒齒研齒條
品質等級 JIS 2

材料 S45C
硬度 HRC 50~55°
表面 染黑處理，不含齒部
硬化處理後四面研磨與齒研
總齒距誤差： $F_p/1000 \leq 0.036$ mm
無鑽孔處理，品號為 -N

Series CSTGH-JIS2 Straight Teeth Ground Racks
Quality Grade JIS 2

Material S45C
Hardness: HRC 50~55°
Surfaces: Black-coated (Exclude Teeth)
Ground on all sides after hardening.
Total Pitch Error: $F_p/1000 \leq 0.036$ mm
No Mounted Holes, Code with -N

型號 Code	模數 Module	L	齒數 No. of Teeth	B	A0	A1	D	l	孔數 No. of Holes	螺絲 Screw	A	$\phi d1$	ϕD	E	f	F_{ta} kN	KG
CSTGH01005-JIS2	1	499.51	159	10	12	11	24.76	150	4	M4	5	4.5	*	*	1.5	2.03	0.4
CSTGH01005-JIS2-N	1	499.51	159	10	12	11	*	*	*	*	*	*	*	*	1.5	2.03	0.4
CSTGH01505-JIS2	1.5	499.51	106	15	20	18.5	24.76	150	4	M5	8	6	10	6	1.5	4.52	1.1
CSTGH01505-JIS2-N	1.5	499.51	106	15	20	18.5	*	*	*	*	*	*	*	*	1.5	4.52	1.1
CSTGH01510-JIS2	1.5	999.03	212	15	20	18.5	49.51	180	6	M5	8	6	10	6	1.5	4.58	2.1
CSTGH01510-JIS2-N	1.5	999.03	212	15	20	18.5	*	*	*	*	*	*	*	*	1.5	4.58	2.1
CSTGH02005-JIS2	2	502.65	80	20	25	23	26.33	150	4	M6	10	7	11	7	2	7.96	1.8
CSTGH02005-JIS2-N	2	502.65	80	20	25	23	*	*	*	*	*	*	*	*	2	7.96	1.8
CSTGH02010-JIS2	2	1005.31	160	20	25	23	52.65	180	6	M6	10	7	11	7	2	8.11	3.6
CSTGH02010-JIS2-N	2	1005.31	160	20	25	23	*	*	*	*	*	*	*	*	2	8.11	3.6
CSTGH02505-JIS2	2.5	502.65	64	25	30	27.5	26.33	150	4	M8	12	9	14	8.6	2	12.34	2.7
CSTGH02505-JIS2-N	2.5	502.65	64	25	30	27.5	*	*	*	*	*	*	*	*	2	12.34	2.7
CSTGH02510-JIS2	2.5	1005.31	128	25	30	27.5	52.65	180	6	M8	12	9	14	8.6	2	12.61	5.4
CSTGH02510-JIS2-N	2.5	1005.31	128	25	30	27.5	*	*	*	*	*	*	*	*	2	12.61	5.4
CSTGH03005-JIS2	3	499.51	53	30	35	32	24.76	150	4	M10	14	11	17.5	10.8	2	17.63	3.7
CSTGH03005-JIS2-N	3	499.51	53	30	35	32	*	*	*	*	*	*	*	*	2	17.63	3.7
CSTGH03010-JIS2	3	999.03	106	30	35	32	49.51	180	6	M10	14	11	17.5	10.8	2	18.07	7.5
CSTGH03010-JIS2-N	3	999.03	106	30	35	32	*	*	*	*	*	*	*	*	2	18.07	7.5
CSTGH04005-JIS2	4	502.65	40	40	45	41	26.33	150	4	M12	18	14	20	13	2	34.76	6.4
CSTGH04005-JIS2-N	4	502.65	40	40	45	41	*	*	*	*	*	*	*	*	2	34.76	7.2
CSTGH04010-JIS2	4	1005.31	80	40	45	41	52.65	180	6	M12	18	14	20	13	2	35.82	12.9
CSTGH04010-JIS2-N	4	1005.31	80	40	45	41	*	*	*	*	*	*	*	*	2	35.82	14.5
CSTGH05005-JIS2	5	502.65	32	50	50	45	31.33	220	3	M14	20	16	23	15.2	3	47.68	8.9
CSTGH05005-JIS2-N	5	502.65	32	50	50	45	*	*	*	*	*	*	*	*	3	47.68	8.9
CSTGH05010-JIS2	5	1005.31	64	50	50	45	62.65	220	5	M14	20	16	23	15.2	3	49.36	17.9
CSTGH05010-JIS2-N	5	1005.31	64	50	50	45	*	*	*	*	*	*	*	*	3	49.36	17.9
CSTGH06005-JIS2	6	490.09	26	60	60	54	25.04	220	3	M16	23	18	26	17.5	3	67.80	12.5
CSTGH06005-JIS2-N	6	490.09	26	60	60	54	*	*	*	*	*	*	*	*	3	67.80	12.5
CSTGH06010-JIS2	6	999.03	53	60	60	54	59.51	220	5	M16	23	18	26	17.5	3	70.51	25.5
CSTGH06010-JIS2-N	6	999.03	53	60	60	54	*	*	*	*	*	*	*	*	3	70.51	25.5

※ 重量僅供參考，實重須經實秤為準。

※ Weight only for reference. Actual scale should be Weighing.

MSTMQ-JIS4-N

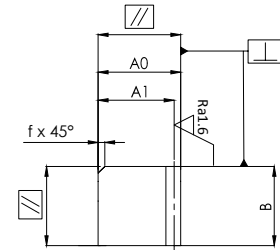
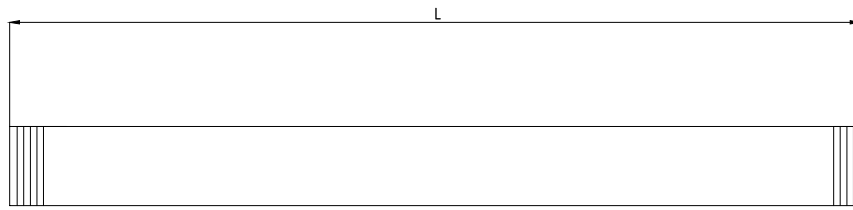

單位 / Dimension : mm

系列 MSTMQ-JIS4-N 直齒調質齒條
品質等級 JIS 4

Series MSTMQ-JIS4-N Straight Quenched & Tempered Racks
Quality Grade JIS 4

材料 SCM440
硬度 HRC 18~22°
表面 染黑處理
總齒距誤差 : $F_p/1000 \leq 0.075\text{mm}$
無鑽孔處理 · 品號為 -N

Material SCM440
Hardness: HRC 18~22°
Surfaces: Black-coated
Total Pitch Error: $F_p/1000 \leq 0.075\text{mm}$
No Mounted Holes , Code with-N

型號 Code	模數 Module	L	齒數 No. of Teeth	B	A0	A1	f	F_{ta} kN	KG
MSTMQ01510-JIS4-N	1.5	999.03	212	15	20	18.5	1.5	5.36	2.1
MSTMQ02010-JIS4-N	2	1005.31	160	20	25	23	2	9.48	3.6
MSTMQ02510-JIS4-N	2.5	1005.31	128	25	30	27.5	2	14.73	5.4
MSTMQ03010-JIS4-N	3	999.03	106	30	35	32	2	21.12	7.5
MSTMQ04010-JIS4-N	4	1005.31	80	45	45	41	2	41.86	14.5
MSTMQ05010-JIS4-N	5	1005.31	64	50	50	45	3	57.68	17.9
MSTMQ06010-JIS4-N	6	999.03	53	60	60	54	3	82.40	25.5

CSTM-JIS4

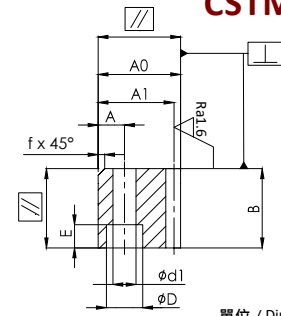
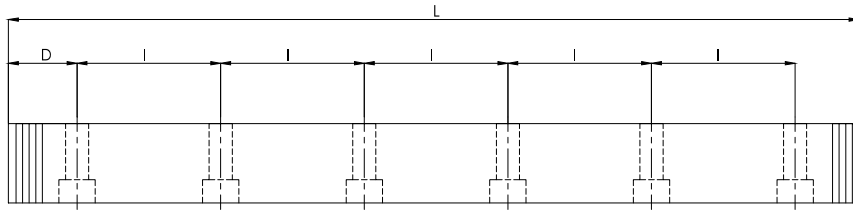

單位 / Dimension : mm

系列 CSTM-JIS4 直齒齒條
品質等級 JIS 4

Series CSTM-JIS4 Straight Milled Racks
Quality Grade JIS 4

材料 S45C
硬度 HRC 10~12°
表面 染黑處理
總齒距誤差 : $F_p/1000 \leq 0.075\text{mm}$
無鑽孔處理 · 品號為 -N

Material S45C
Hardness: HRC 10~12°
Surfaces: Black-coated
Total Pitch Error: $F_p/1000 \leq 0.075\text{mm}$
No Mounted Holes, Code with-N

型號 Code	模數 Module	L	齒數 No. of Teeth	B	A0	A1	D	l	孔數 No. of Holes	螺絲 Screw	A	φd1	φD	E	f	F _{ta} kN	KG
CSTM01510-JIS4	1.5	999.03	212	15	20	18.5	49.51	180	6	M5	8	6	10	6	1.5	3.20	2.1
CSTM01510-JIS4-N	1.5	999.03	212	15	20	18.5	*	*	*	*	*	*	*	*	1.5	3.20	2.1
CSTM01511-JIS4-N	1.5	999.03	212	15	15	13.5	*	*	*	*	*	*	*	*	1.5	3.20	1.6
CSTM01520-JIS4-N	1.5	2049.88	435	15	20	18.5	*	*	*	*	*	*	*	*	1.5	3.20	4.4
CSTM02010-JIS4	2	1005.31	160	20	25	23	52.65	180	6	M6	10	7	11	7	2	5.66	3.6
CSTM02010-JIS4-N	2	1005.31	160	20	25	23	*	*	*	*	*	*	*	*	2	5.66	3.6
CSTM02011-JIS4	2	1005.31	160	20	20	18	52.65	180	6	M6	7	7	11	7	2	5.66	2.9
CSTM02011-JIS4-N	2	1005.31	160	20	20	18	*	*	*	*	*	*	*	*	2	5.66	2.9
CSTM02020-JIS4	2	2048.31	326	20	25	23	34.15	180	12	M6	10	7	11	7	2	5.72	7.3
CSTM02020-JIS4-N	2	2048.31	326	20	25	23	*	*	*	*	*	*	*	*	2	5.72	7.3
CSTM02021-JIS4-N	2	2048.31	326	20	20	18	*	*	*	*	*	*	*	*	2	5.72	5.8
CSTM02510-JIS4	2.5	1005.31	128	25	30	27.5	52.65	180	6	M8	12	9	14	8.6	2	8.80	5.4
CSTM02510-JIS4-N	2.5	1005.31	128	25	30	27.5	*	*	*	*	*	*	*	*	2	8.80	5.4
CSTM02511-JIS4	2.5	1005.31	128	25	25	22.5	52.65	180	6	M8	9	9	14	8.6	2	8.80	4.5
CSTM02511-JIS4-N	2.5	1005.31	128	25	25	22.5	*	*	*	*	*	*	*	*	2	8.80	4.5
CSTM02520-JIS4	2.5	2049.88	261	25	30	27.5	34.94	180	12	M8	12	9	14	8.6	2	8.91	10.9
CSTM02520-JIS4-N	2.5	2049.88	261	25	30	27.5	*	*	*	*	*	*	*	*	2	8.91	10.9
CSTM02521-JIS4-N	2.5	2049.88	261	25	25	22.5	*	*	*	*	*	*	*	*	2	8.91	9.1
CSTM03010-JIS4	3	999.03	106	30	35	32	49.51	180	6	M10	14	11	17.5	10.8	2	12.61	7.5
CSTM03010-JIS4-N	3	999.03	106	30	35	32	*	*	*	*	*	*	*	*	2	12.61	7.5
CSTM03011-JIS4	3	999.03	106	30	30	27	49.51	180	6	M10	11	11	17.5	10.8	2	12.61	6.4
CSTM03011-JIS4-N	3	999.03	106	30	30	27	*	*	*	*	*	*	*	*	2	12.61	6.4
CSTM03020-JIS4	3	2045.17	217	30	35	32	32.58	180	12	M10	14	11	17.5	10.8	2	12.80	15.3
CSTM03020-JIS4-N	3	2045.17	217	30	35	32	*	*	*	*	*	*	*	*	2	12.80	15.3
CSTM03021-JIS4-N	3	2045.17	217	30	30	27	*	*	*	*	*	*	*	*	2	12.80	13.1
CSTM04010-JIS4	4	1005.31	80	40	45	41	52.65	180	6	M12	18	14	20	13	2	22.21	12.9
CSTM04010-JIS4-N	4	1005.31	80	40	45	41	*	*	*	*	*	*	*	*	2	22.21	12.9
CSTM04011-JIS4	4	1005.31	80	40	40	36	52.65	180	6	M12	15	14	20	13	2	22.21	11.4
CSTM04011-JIS4-N	4	1005.31	80	40	40	36	*	*	*	*	*	*	*	*	2	22.21	11.4
CSTM04020-JIS4	4	2048.31	163	40	45	41	34.15	180	12	M12	18	14	20	13	2	22.63	26.2
CSTM04020-JIS4-N	4	2048.31	163	40	45	41	*	*	*	*	*	*	*	*	2	22.63	26.2
CSTM05010-JIS4	5	1005.31	64	50	50	45	62.65	220	5	M14	20	16	23	15.2	3	34.44	17.9
CSTM05010-JIS4-N	5	1005.31	64	50	50	45	*	*	*	*	*	*	*	*	3	34.44	17.9
CSTM05020-JIS4	5	2042.04	130	50	50	45	31.02	220	10	M14	20	16	23	15.2	3	35.20	36.3
CSTM05020-JIS4-N	5	2042.04	130	50	50	45	*	*	*	*	*	*	*	*	3	35.20	36.3
CSTM06010-JIS4	6	999.03	53	60	60	54	59.51	220	5	M16	23	18	26	17.5	3	49.19	25.5
CSTM06010-JIS4-N	6	999.03	53	60	60	54	*	*	*	*	*	*	*	*	3	49.19	25.5
CSTM06020-JIS4	6	2035.75	108	60	60	54	27.88	220	10	M16	23	18	26	17.5	3	50.46	52.1
CSTM06020-JIS4-N	6	2035.75	108	60	60	54	*	*	*	*	*	*	*	*	3	50.46	52.1

※ 重量僅供參考 · 實重須經實秤為準。

※ Weight only for reference. Actual scale should be Weighing.

CSTMH-JIS5

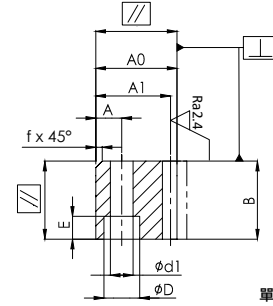
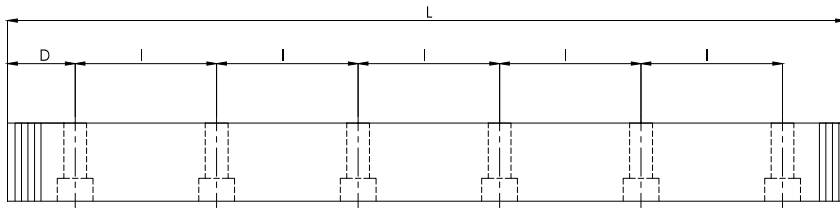

單位 / Dimension : mm

系列 CSTMH-JIS5 直齒高週波齒條
品質等級 JIS 5

Series CSTMH-JIS5 Straight Hardened Racks
Quality Grade JIS 5

材料 S45C
硬度 HRC 50~55°
表面 染黑處理
總齒距誤差 $F_p/1000 \leq 0.15\text{mm}$
無鑽孔處理 · 品號為 -N

Material S45C
Hardness: HRC 50~55°
Surfaces: Black-coated
Total Pitch Error: $F_p/1000 \leq 0.15\text{mm}$
No Mounted Holes, Code with-N

型號 Code	模數 Module	L	齒數 No. of Teeth	B	A0	A1	D	I	孔數 No. of Holes	螺絲 Screw	A	φd1	φD	E	f	F _{ta} kN	KG
CSTMH01510-JIS5	1.5	999.03	212	15	20	18.5	49.51	180	6	M5	8	6	10	6	1.5	3.60	2.1
CSTMH01510-JIS5-N	1.5	999.03	212	15	20	18.5	*	*	*	*	*	*	*	*	1.5	3.60	2.1
CSTMH01511-JIS5-N	1.5	999.03	212	15	15	13.5	*	*	*	*	*	*	*	*	1.5	3.60	1.6
CSTMH01520-JIS5-N	1.5	2049.88	435	15	20	18.5	*	*	*	*	*	*	*	*	1.5	3.63	4.4
CSTMH02010-JIS5	2	1005.31	160	20	25	23	52.65	180	6	M6	10	7	11	7	2	6.37	3.6
CSTMH02010-JIS5-N	2	1005.31	160	20	25	23	*	*	*	*	*	*	*	*	2	6.37	3.6
CSTMH02011-JIS5-N	2	1005.31	160	20	20	18	*	*	*	*	*	*	*	*	2	6.37	2.9
CSTMH02020-JIS5-N	2	2048.31	326	20	25	23	*	*	*	*	*	*	*	*	2	6.44	7.3
CSTMH02021-JIS5-N	2	2048.31	326	20	20	18	*	*	*	*	*	*	*	*	2	6.44	5.8
CSTMH02510-JIS5	2.5	1005.31	128	25	30	27.5	52.65	180	6	M8	12	9	14	8.6	2	9.91	5.4
CSTMH02510-JIS5-N	2.5	1005.31	128	25	30	27.5	*	*	*	*	*	*	*	*	2	9.91	5.4
CSTMH02511-JIS5-N	2.5	1005.31	128	25	25	22.5	*	*	*	*	*	*	*	*	2	9.91	4.5
CSTMH02520-JIS5-N	2.5	2049.88	261	25	30	27.5	*	*	*	*	*	*	*	*	2	10.30	10.9
CSTMH02521-JIS5-N	2.5	2049.88	261	25	25	22.5	*	*	*	*	*	*	*	*	2	10.30	9.1
CSTMH03010-JIS5	3	999.03	106	30	35	32	49.51	180	6	M10	14	11	17.5	10.8	2	14.20	7.5
CSTMH03010-JIS5-N	3	999.03	106	30	35	32	*	*	*	*	*	*	*	*	2	14.20	7.5
CSTMH03011-JIS5-N	3	999.03	106	30	30	27	*	*	*	*	*	*	*	*	2	14.20	6.4
CSTMH03020-JIS5-N	3	2045.17	217	30	35	32	*	*	*	*	*	*	*	*	2	14.41	15.3
CSTMH03021-JIS5-N	3	2045.17	217	30	30	27	*	*	*	*	*	*	*	*	2	14.41	13.1
CSTMH04010-JIS5	4	1005.31	80	40	45	41	52.65	180	6	M12	18	14	20	13	2	25.02	12.9
CSTMH04010-JIS5-N	4	1005.31	80	40	45	41	*	*	*	*	*	*	*	*	2	25.02	12.9
CSTMH04010-JIS5-N	4	1005.31	80	40	40	36	*	*	*	*	*	*	*	*	2	25.02	11.4
CSTMH04020-JIS5-N	4	2048.31	163	40	45	41	*	*	*	*	*	*	*	*	2	25.49	26.2
CSTMH05010-JIS5	5	1005.31	64	50	50	45	62.65	180	5	M14	20	16	23	15.2	3	38.78	17.9
CSTMH05010-JIS5-N	5	1005.31	64	50	50	45	*	*	*	*	*	*	*	*	3	38.78	17.9
CSTMH05020-JIS5-N	5	2042.04	130	50	50	45	*	*	*	*	*	*	*	*	3	39.64	36.3
CSTMH06010-JIS5	6	999.03	53	60	60	54	59.51	180	5	M16	23	18	26	17.5	3	55.40	25.5
CSTMH06010-JIS5-N	6	999.03	53	60	60	54	*	*	*	*	*	*	*	*	3	55.40	25.5
CSTMH06020-JIS5-N	6	2035.75	108	60	60	54	*	*	*	*	*	*	*	*	3	56.82	52.1

MSTGQ-CP-JIS1

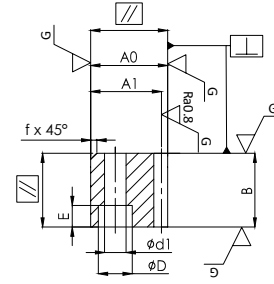
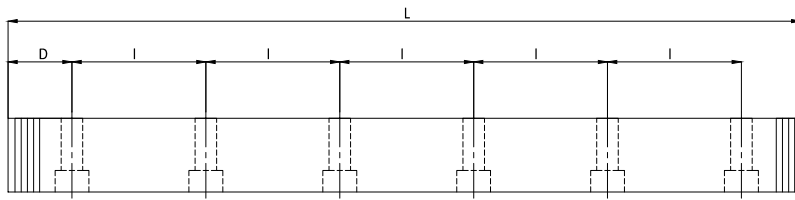

單位 / Dimension : mm

系列 MSTGQ-CP-JIS1 直齒調質齒研齒條
品質等級 JIS 1

Series MSTGQ-CP-JIS1 Straight Quenched & Tempered Ground Racks
Quality Grade JIS 1

材料 SCM440
硬度 HRC 18~22°
總齒距誤差 : $F_p/1000 \leq 0.033\text{mm}$
調質處理後四面研磨與齒研
無鑽孔處理 · 品號為 -N
室溫在攝氏 25° 為準

Material SCM440
Hardness: HRC 18~22°
Total Pitch Error: $F_p/1000 \leq 0.033\text{mm}$
Ground on all sides after quenching.
No Mounted Holes , Code with-N
Room Temperature is 25°C

型號 Code	周節 CP	模數 Module	L	齒數 No. of Teeth	B	A0	A1	D	l	孔數 No. of Holes	螺絲 Screw	A	$\phi d1$	ϕD	E	f	F_{ta} kN	KG
MSTGQ-CP-05005-JIS1	5	1.5915	500	100	15	20	18.41	40	140	4	M5	8	6	10	6	1.5	3.95	1.1
MSTGQ-CP-05005-JIS1-N	5	1.5915	500	100	15	20	18.41	*	*	*	*	*	*	*	*	1.5	3.95	1.1
MSTGQ-CP-05010-JIS1-N	5	1.5915	1000	200	15	20	18.41	*	*	*	*	*	*	*	*	1.5	4.01	2.1
MSTGQ-CP-10005-JIS1	10	3.1831	500	50	30	35	31.82	40	140	4	M10	14	11	17.5	10.8	1.5	15.38	3.7
MSTGQ-CP-10005-JIS1-N	10	3.1831	500	50	30	35	31.82	*	*	*	*	*	*	*	*	1.5	15.38	3.7
MSTGQ-CP-10010-JIS1-N	10	3.1831	1000	100	30	35	31.82	*	*	*	*	*	*	*	*	1.5	15.78	7.5

齒研 Straight JIS

※ 重量僅供參考 · 實重須經實秤為準。

※ Weight only for reference. Actual scale should be Weighing.

MSTGH-CP-JIS1

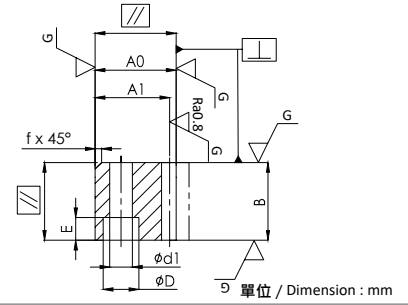
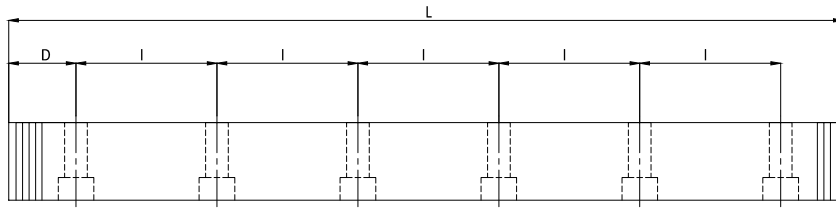

系列 MSTGH-CP-JIS1 直齒齒研齒條
品質等級 JIS 1

Series MSTGH-CP-JIS1 Straight Teeth Ground Racks
Quality Grade JIS 1

材料 SCM440
硬度 HRC 55~58°
硬化處理後四面研磨與齒研
總齒距誤差： $F_p/1000 \leq 0.033\text{mm}$
無鑽孔處理，品號為 -N
室溫在攝氏 25° 為準

Material SCM440
Hardness: HRC 55~58°
Ground on all sides after hardening.
Total Pitch Error: $F_p/1000 \leq 0.033\text{mm}$
No Mounted Holes, Code with-N
Room Temperature is 25°

型號 Code	周節 CP	模數 Module	L	齒數 No. of Teeth	B	A0	A1	D	l	孔數 No. of Holes	螺絲 Screw	A	φd1	φD	E	f	F _{ta} kN	KG
MSTGH-CP-05005-JIS1	5	1.5915	500	100	15	20	18.41	25	150	4	M5	8	6	10	6	1.5	6.61	1.1
MSTGH-CP-05005-JIS1-N	5	1.5915	500	100	15	20	18.41	*	*	*	*	*	*	*	*	1.5	6.61	1.1
MSTGH-CP-05010-JIS1	5	1.5915	1000	200	15	20	18.41	50	180	6	M5	8	6	10	6	1.5	6.71	2.1
MSTGH-CP-05010-JIS1-N	5	1.5915	1000	200	15	20	18.41	*	*	*	*	*	*	*	*	1.5	6.71	2.1
MSTGH-CP-10005-JIS1	10	3.1831	500	50	30	35	31.82	25	150	4	M10	14	11	17.5	10.8	1.5	25.76	3.7
MSTGH-CP-10005-JIS1-N	10	3.1831	500	50	30	35	31.82	*	*	*	*	*	*	*	*	1.5	25.76	3.7
MSTGH-CP-10010-JIS1	10	3.1831	1000	100	30	35	31.82	50	180	6	M10	14	11	17.5	10.8	1.5	26.44	7.5
MSTGH-CP-10010-JIS1-N	10	3.1831	1000	100	30	35	31.82	*	*	*	*	*	*	*	*	1.5	26.44	7.5

CSTM-CP-JIS4

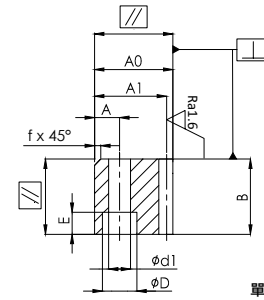
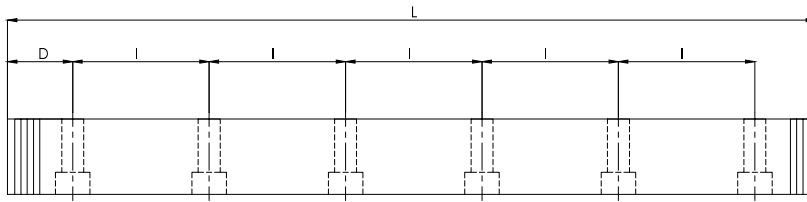

單位 / Dimension : mm

系列 CSTM-CP-JIS4 直齒精銑齒條
品質等級 JIS 4

Series CSTM-CP-JIS4 Straight Milled Racks
Quality Grade JIS 4

材料 S45C
硬度 HRC 10~12°
表面 染黑處理
總齒距誤差 : $F_p / 1000 \leq 0.075\text{mm}$
無鑽孔處理 · 品號為 -N

Material S45C
Hardness: HRC 10~12°
Surfaces: Black-coated
Total Pitch Error: $F_p / 1000 \leq 0.075\text{mm}$
No Mounted Holes , Code with-N

型號 Code	周節 CP	模數 Module	L	齒數 No. of Teeth	B	A0	A1	D	l	孔數 No. of Holes	螺絲 Screw	A	ød1	øD	E	f	F _{ta} kN	KG
CSTM-CP-05005-JIS4-N	5	1.5915	500	100	15	20	18.41	*	*	*	*	*	*	*	*	1	3.34	1.1
CSTM-CP-05010-JIS4	5	1.5915	1000	200	15	20	18.41	50	180	6	M5	8	6	10	6	1	3.39	2.0
CSTM-CP-05010-JIS4-N	5	1.5915	1000	200	15	20	18.41	*	*	*	*	*	*	*	*	1	3.39	2.1
CSTM-CP-05015-JIS4	5	1.5915	1500	300	15	20	18.41	30	180	9	M5	8	6	10	6	1	3.41	3.0
CSTM-CP-05015-JIS4-N	5	1.5915	1500	300	15	20	18.41	*	*	*	*	*	*	*	*	1	3.41	3.2
CSTM-CP-05020-JIS4	5	1.5915	2050	410	15	20	18.41	35	180	12	M5	8	6	10	6	1	3.42	4.1
CSTM-CP-05020-JIS4-N	5	1.5915	2050	410	15	20	18.41	*	*	*	*	*	*	*	*	1	3.42	4.4
CSTM-CP-10005-JIS4-N	10	3.1831	500	50	30	35	31.82	*	*	*	*	*	*	*	*	2	13.01	3.7
CSTM-CP-10010-JIS4	10	3.1831	1000	100	30	35	31.82	50	180	6	M10	14	11	17.5	10.8	2	13.36	7.1
CSTM-CP-10010-JIS4-N	10	3.1831	1000	100	30	35	31.82	*	*	*	*	*	*	*	*	2	13.36	7.5
CSTM-CP-10015-JIS4	10	3.1831	1500	150	30	35	31.82	30	180	9	M10	14	11	17.5	10.8	2	13.49	10.6
CSTM-CP-10015-JIS4-N	10	3.1831	1500	150	30	35	31.82	*	*	*	*	*	*	*	*	2	13.49	11.2
CSTM-CP-10020-JIS4	10	3.1831	2050	205	30	35	31.82	35	180	12	M10	14	11	17.5	10.8	2	13.56	14.4
CSTM-CP-10020-JIS4-N	10	3.1831	2050	205	30	35	31.82	*	*	*	*	*	*	*	*	2	13.56	15.3
CSTM-CP-15005-JIS4-N	15	4.7746	495	33	50	50	45.23	*	*	*	*	*	*	*	*	2	31.84	8.8
CSTM-CP-15010-JIS4	15	4.7746	1005	67	50	50	45.23	62.5	220	5	M14	20	16	23	15.2	2	32.94	16.9
CSTM-CP-15010-JIS4-N	15	4.7746	1005	67	50	50	45.23	*	*	*	*	*	*	*	*	2	32.94	17.9
CSTM-CP-15015-JIS4	15	4.7746	1500	100	50	50	45.23	90	220	7	M14	20	16	23	15.2	2	33.39	25.2
CSTM-CP-15015-JIS4-N	15	4.7746	1500	100	50	50	45.23	*	*	*	*	*	*	*	*	2	33.39	26.6
CSTM-CP-15020-JIS4	15	4.7746	2040	136	50	50	45.23	30	220	10	M14	20	16	23	15.2	2	33.65	34.2
CSTM-CP-15020-JIS4-N	15	4.7746	2040	136	50	50	45.23	*	*	*	*	*	*	*	*	2	33.65	36.2
CSTM-CP-20005-JIS4-N	20	6.3662	500	25	60	60	53.63	*	*	*	*	*	*	*	*	3	50.05	12.8
CSTM-CP-20010-JIS4	20	6.3662	1000	50	60	60	53.63	60	220	5	M16	23	18	26	17.5	3	52.06	24.2
CSTM-CP-20010-JIS4-N	20	6.3662	1000	50	60	60	53.63	*	*	*	*	*	*	*	*	3	52.06	25.6
CSTM-CP-20015-JIS4	20	6.3662	1500	75	60	60	53.63	90	220	7	M16	23	18	26	17.5	3	52.92	36.2
CSTM-CP-20015-JIS4-N	20	6.3662	1500	75	60	60	53.63	*	*	*	*	*	*	*	*	3	52.92	38.4
CSTM-CP-20020-JIS4	20	6.3662	2040	102	60	60	53.63	30	220	10	M16	23	18	26	17.5	3	53.45	49.3
CSTM-CP-20020-JIS4-N	20	6.3662	2040	102	60	60	53.63	*	*	*	*	*	*	*	*	3	53.45	52.2

直齒精銑齒條
Straight Milled Racks
JIS

標準直齒條和齒輪定義

Definition of Standard Straight Gear

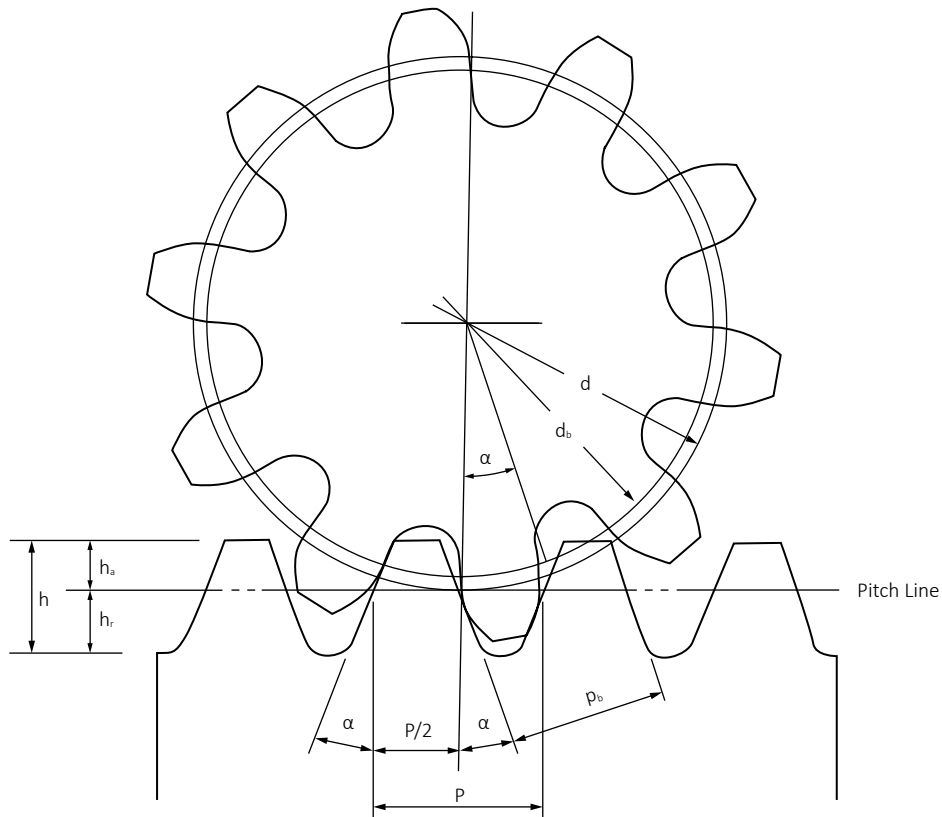

標準直齒輪

模數	m
壓力角	$\alpha = 20^\circ$
齒冠高	$h_a = m$
齒根高	$h_r \geq 1.25m$
齒全深	$h \geq 2.25m$
有效齒深	$h_w = 2.00m$
齒頂隙	$c = 0.25m$
標準節距	$p = \pi m$
基圓節距	$p_b = p \cos \alpha$
標準圓直徑	$d = mz$
基圓直徑	$d_b = d \cos \alpha$
$r_f = R$ 角	
S= 齒厚	

Module	m
Pressure Angle	$\alpha = 20^\circ$
Addendum	$h_a = m$
Dedendum	$h_r \geq 1.25m$
Whole Depth	$h \geq 2.25m$
Working Tooth Depth	$h_w = 2.00m$
Clearance	$c = 0.25m$
Circular Pitch	$p = \pi m$
Base Circle Pitch	$p_b = p \cos \alpha$
Standard Circle Dia	$d = mz$
Base Circle Diameter	$d_b = d \cos \alpha$
$r_f =$ Root Radius	
S= Circular Tooth Thickness	



圖 1-1 ISO 53 針對基本公制齒條的模數 1 進行標準化
Fig. 1-1 The Basic Metric Rack From ISO 53 Normalized for Module 1



圖 1-2 基本英制徑節齒條的 DP1 進行標準化
Fig. 1-2 The Basic Inch Diametral Pitch Rack Normalized for 1 Diametral Pitch

齒輪與齒條的強度計算公式

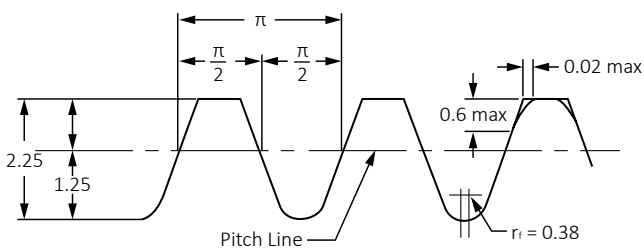
齒輪和齒條的強度通常用彎曲強度和表面耐久性來說明。兩者在應用上都很重要。特別是，當應用環境嚴格時，每個參數都需要進一步討論。

以下公式基於 JGMA (日本齒輪製造商協會) 的標準。以下規格僅供參考。

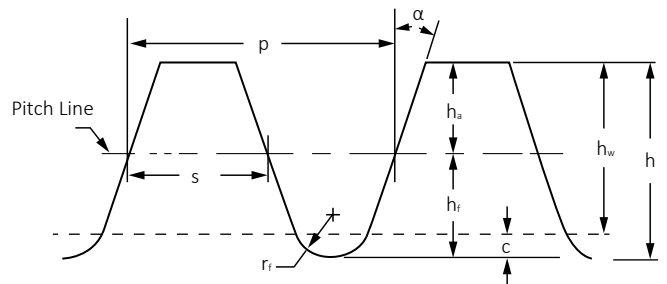
JGMA 401-01 直齒與斜齒彎曲強度計算公式
JGMA 402-01 直齒與斜齒表面耐久性計算公式

彎曲強度和耐久性規格通常用於製造業中的直齒和斜齒 (包括齒條和齒輪)，範圍如下：

模數： m 1.5 to 25 mm
節圓直徑： d 25 to 3200 mm
切向速度： v ≤ 25 m/秒
迴轉速度： n ≤ 3600 rpm

轉換公式：功率、扭矩和力
齒輪強度和耐用性與功率和力的傳輸有關。切向力的計算基於節圓、 F_t (kgf)、功率 P (kw) 和扭矩 T (kgf•m)。

參考公式如下：

$$F_t = \frac{102P}{v} = \frac{19.5 \times 10^6 P}{d_w n} = \frac{2000T}{d_w}$$

$$P = \frac{F_t}{102} = \frac{10^{-6}}{1.95} F_t d_w n$$

$$T = \frac{F_t d_w}{2000} = \frac{947P}{n}$$

其中，咬合節圓直徑的水平切向速度

$$V = \frac{d_w n}{19100} \text{ (m/sec)}$$

dw: 咬合的節圓直徑 (mm)
n: 迴轉速度 (rpm)

產品選用計算：

1. 上述切向力 F_t 的計算方法，可依據不同輸入條件計算出 F_t 值的大小；
2. 型錄中各項產品提供最大允許切向力 F_{ta} 給使用者作設計上的比對；
3. 使用 F_{ta} 時，依據使用條件不同，需配合目錄上所提供的負荷係數 K_a 和壽命係數 K_L 進行修正；

$$F'_{ta} = \frac{F_{ta}}{K_a \times K_L}$$

4. F_t 值須小於 F'_{ta} ；
5. 留意產品型錄上的 F_{ta} 單位為 kN，而切向力 F_t 的計算單位為 kgf，比對時須進行單位轉換。

備註：

- 1 公斤力 = 9.807 牛頓 = 0.0098 千牛頓
- 1 千牛頓 = 101.972 公斤力

Strength and Durability of Gears

The strength of gears is commonly illustrated with bending strength and surface durability. Both are important on application. In particularly, when applications are severe, each parameter requires further discussion.

The following formulas are based on standards of JGMA (Japanese Gear Manufacturer Association). The specifications below are for reference only.

JGMA 401-01 Bending Strength Formula of Spur Gears and Helical Gears
JGMA 402-01 Surface Durability Formula of Spur Gears and Helical Gears

Bending strength and durability specifications are usually used with straight and helical gears (including racks and pinions) in manufacturing industry within the ranges below:

Module: m 1.5 to 25 mm
Pitch Diameter: d 25 to 3200 mm
Tangential Speed: v ≤ 25 m/sec
Rotating Speed: n ≤ 3600 rpm

Conversion Formulas: Power, Torque and Force
Gear strength and durability relate to the power and forces to be transmitted. The calculation of tangential force are based on pitch circle, F_t (kgf), power, P(kw), and torque, T(kgf•m).

Formula Below:

$$F_t = \frac{102P}{v} = \frac{19.5 \times 10^6 P}{d_w n} = \frac{2000T}{d_w}$$

$$P = \frac{F_t}{102} = \frac{10^{-6}}{1.95} F_t d_w n$$

$$T = \frac{F_t d_w}{2000} = \frac{947P}{n}$$

Where v: Tangential Speed of Working Pitch Circle

$$V = \frac{d_w n}{19100} \text{ (m/sec)}$$

dw: Working Pitch Diameter (mm)
n: Rotating Speed (rpm)

Product Selection Calculation:

1. The calculation method of the above tangential force F_t can be calculated according to different input conditions;
2. Each item in the catalogue provides the maximum allowable tangential force F_{ta} for the design comparison for users;
3. When using F_{ta} , depending on the conditions of use, it is necessary to correct the load factor K_a and the life factor K_L provided in the catalog;

$$F'_{ta} = \frac{F_{ta}}{K_a \times K_L}$$

4. F_t value must be less than F'_{ta}
5. Note that the F_{ta} unit on the product catalog is kN, and the tangential force F_t is calculated in kgf, and the unit conversion is required when comparing.

Remark:

- 1kgf= 9.807 N= 0.0098 kN
- 1kN= 101.972 kgf

硬度對照表

Steel Hardness Conversion Chart

布氏 Brinell HB	洛氏 Rockwell HRC	洛氏 Rockwell HRB	維氏 Vickers HV
760	70		
752	69		
745	68		
746	67		
735	66		
711	65		
695	64		
681	63		
658	62		
642	61		
627	60		
613	59		
601	58	746	
592	57	727	
572	56	694	
552	55	649	
534	54	120	589
513	53	119	567
504	52	118	549
486	51	118	531
469	50	117	505
468	49	117	497
456	48	116	490
445	47	115	474
430	46	115	458
419	45	114	448
415	44	114	438
402	43	114	424
388	42	113	406
375	41	112	393
373	40	111	388
360	39	111	376
348	38	110	361
341	37	109	351
331	36	109	342
322	35	108	332
314	34	108	320
308	33	107	311
300	32	107	303
290	31	106	292
277	30	105	285
271	29	104	277
264	28	103	271
262	27	103	262
255	26	102	258
250	25	101	255
245	24	100	252
240	23	100	247
233	22	99	241
229	21	98	235
223	20	97	227
216	19	96	222
212	18	95	218
208	17	95	210

硬度對照表

Steel Hardness Conversion Chart

布氏 Brinell HB	洛氏 Rockwell HRC	洛氏 Rockwell HRB	維氏 Vickers HV
199	15	93	199
191	14	92	197
190	13	92	186
186	12	91	184
183	11	90	183
180	10	89	180
175	9	88	178
170	7	87	175
167	6	86	172
166	5	86	168
163	4	85	162
160	3	84	160
156	2	83	158
154	1	82	152

由於各家材料與檢測儀器不同，所有數值僅供參考。
 Since all materials and testing instruments are different, all values are for reference only.

齒距和模數轉換表
Conversion Table for Gear Pitch and Module

Conversion Table 1				Conversion Table 2				Conversion Table 3			
Diametral Pitch	Circular Pitch (CP)		Module	Diametral Pitch	Circular Pitch (CP)		Module	Diametral Pitch	Circular Pitch (CP)		Module
DP	in	mm	M	DP	in	mm	M	DP	in	mm	M
1	3.1416	79.796	25.4	3	1.0472	26.599	8.4667	10.6395	0.2953	7.5	2.3873
1.0053	3.1250	79.375	25.2658	3.0691	1.0236	26	8.2761	11	0.2856	7.2540	2.3091
1.0160	3.0921	78.540	25	3.1416	1	25.4	8.0851	11.2889	0.2783	7.0690	2.2500
1.0472	3	76.200	24.2552	3.1750	0.9895	25.133	8	11.3995	0.2756	7	2.2282
1.0583	2.9684	75.398	24	3.1919	0.9843	25	7.9577	12	0.2618	6.6500	2.1167
1.0640	2.9528	75	23.8732	3.2500	0.9666	24.553	7.8154	12.2764	0.2559	6.5	2.0690
1.0927	2.8750	73.025	23.2446	3.3249	0.9449	24	7.6394	12.5664	0.2500	6.3500	2.0213
1.1399	2.7559	70	22.2817	3.3510	0.9375	23.813	7.5798	12.7	0.2474	6.2830	2
1.1424	2.7500	69.850	22.2339	3.5	0.8976	22.799	7.2571	13	0.2417	6.1380	1.9538
1.1545	2.7211	69.115	22	3.5904	0.8750	22.225	7.0744	13.2994	0.2362	6	1.9099
1.1968	2.6250	66.675	21.2233	3.6271	0.8661	22	7.0028	14	0.2244	5.7	1.8143
1.2276	2.5591	65	20.6901	3.6286	0.8658	21.991	7	14.5084	0.2165	5.5	1.7507
1.2500	2.5133	63.837	20.3200	3.7500	0.8378	21.279	6.7733	14.5143	0.2164	5.4980	1.7500
1.2566	2.5	63.5	20.2127	3.8666	0.8125	20.638	6.5691	15	0.2094	5.3200	1.6933
1.2700	2.4737	62.832	20	3.9898	0.7874	20	6.3662	15.9593	0.1969	5	1.5915
1.3228	2.3750	60.325	19.2020	4	0.7854	19.949	6.3500	16	0.1963	4.9870	1.5875
1.3299	2.3622	60	19.0986	4.1888	0.7500	19.050	6.0638	16.7552	0.1875	4.7630	1.5160
1.3963	2.2500	57.150	18.1914	4.1998	0.7480	19	6.0479	16.9333	0.1855	4.7120	1.5
1.4111	2.2263	56.549	18	4.2333	0.7421	18.850	6	17.7325	0.1772	4.5	1.4324
1.4508	2.1654	55	17.5070	4.4331	0.7087	18	5.7296	18	0.1745	4.4330	1.4111
1.4784	2.1250	53.975	17.1808	4.5	0.6981	17.733	5.6444	19.9491	0.1575	4	1.2732
1.5	2.0944	53.198	16.9333	4.5696	0.6875	17.463	5.5585	20	0.1571	3.9900	1.2700
1.5708	2	50.800	16.1701	4.6182	0.6803	17.279	5.5	20.3200	0.1546	3.9270	1.25
1.5875	1.9790	50.265	16	4.6939	0.6693	17	5.4113	22.7990	0.1378	3.5	1.1141
1.5959	1.9685	50	15.9155	4.9873	0.6299	16	5.0930	24	0.1309	3.3250	1.0583
1.6755	1.8750	47.625	15.1595	5	0.6283	15.959	5.0800	25	0.1257	3.1920	1.0160
1.6933	1.8553	47.124	15	5.0265	0.6250	15.875	5.0532	25.1327	0.1250	3.1750	1.0106
1.7500	1.7952	45.598	14.5143	5.0800	0.6184	15.708	5	25.4	0.1237	3.1420	1
1.7733	1.7717	45	14.3239	5.3198	0.5906	15	4.7746	26.5988	0.1181	3	0.9549
1.7952	1.7500	44.450	14.1489	5.5	0.5712	14.508	4.6182	28	0.1122	2.8500	0.9071
1.8143	1.7316	43.982	14	5.5851	0.5625	14.288	4.5479	30	0.1047	2.6600	0.8467
1.9333	1.6250	41.275	13.1382	5.6444	0.5566	14.137	4.5	31.4159	0.1	2.5400	0.8085
1.9538	1.6079	40.841	13	5.6997	0.5512	14	4.4563	31.7500	0.0989	2.5130	0.8
1.9949	1.5748	40	12.7324	6	0.5236	13.299	4.2333	31.9186	0.0984	2.5	0.7958
2	1.5708	39.898	12.7	6.1382	0.5118	13	4.1380	32	0.0982	2.4940	0.7938
2.0944	1.5	38.1	12.1276	6.2832	0.5	12.7	4.0425	33.8667	0.0928	2.3560	0.7500
2.0999	1.4961	38	12.0958	6.3500	0.4947	12.566	4	36	0.0873	2.2170	0.7056
2.1167	1.4842	37.699	12	6.5	0.4833	12.276	3.9077	36.2857	0.0866	2.1990	0.7
2.1855	1.4375	36.513	11.6223	6.6497	0.4724	12	3.8197	38	0.0827	2.1	0.6684
2.2166	1.4173	36	11.4592	7	0.4488	11.399	3.6286	39.8982	0.0787	2	0.6366
2.2500	1.3963	35.465	11.2889	7.1808	0.4375	11.113	3.5372	40	0.0785	1.9950	0.6350
2.2848	1.3750	34.925	11.1170	7.2542	0.4331	11	3.5014	42.3333	0.0742	1.8850	0.6
2.3091	1.3605	34.558	11	7.2571	0.4329	10.996	3.5	48	0.0654	1.6620	0.5292
2.3470	1.3386	34	10.8225	7.9796	0.3937	10	3.1831	50	0.0628	1.5960	0.5080
2.3936	1.3125	33.338	10.6117	8	0.3927	9.975	3.1750	50.2655	0.0625	1.5880	0.5053
2.4936	1.2598	32	10.1859	8.3776	0.3750	9.525	3.0319	50.8	0.0618	1.5710	0.5
2.5	1.2566	31.919	10.1600	8.3996	0.3740	9.5	3.0239	53.1976	0.0591	1.5	0.4775
2.5133	1.2500	31.750	10.1063	8.4667	0.3711	9.425	3	63.5	0.0495	1.2570	0.4
2.5400	1.2368	31.416	10	8.8663	0.3543	9	2.8648	64	0.0491	1.2470	0.3969
2.6456	1.1875	30.163	9.6010	9	0.3491	8.866	2.8222	72	0.0436	1.1080	0.3528
2.6599	1.1811	30	9.5493	9.2364	0.3401	8.639	2.7500	79.7965	0.0394	1	0.3183
2.7500	1.1424	29.017	9.2364	9.3878	0.3346	8.5	2.7056	80	0.0393	0.9970	0.3175
2.7925	1.1250	28.575	9.0957	9.9746	0.3150	8	2.5465	84.6667	0.0371	0.9420	0.3
2.8222	1.1132	28.274	9	10	0.3142	7.980	2.5400	96	0.0327	0.8310	0.2646
2.8499	1.1024	28	8.9127	10.0531	0.3125	7.938	2.5266	120	0.0262	0.6650	0.2117
2.9568	1.0625	26.988	8.5904	10.1600	0.3092	7.854	2.5	127	0.0247	0.6280	0.2

斜齒齒規安裝規格表
Helical Rack Gauge for Assembling

模數 Module	型號 Code	規格 Dimension	角度 Angle	適用齒條系列 Rack Code Matched
	斜齒齒規左斜 / Helical Gauge Left Hand			
M1	MHTGQ010-JIS-Gauge	8*A15*199.42L*M1	21°30'	MHTGQ010-JIS1
M1.5	CHTGH015-Gauge	17*17*200L*M1.5	19°31'42"	CHTGH015-DIN5 CHTGH015-DIN6 MHTG015-DIN6
	MHTGQ015-JIS-Gauge	12*A20*197.34L*M1.5	21°30'	MHTGQ015-JIS1
M2	CHTM015-Gauge	17*17*200L*M1.5	19°31'42"	CHTM015-DIN8 CHTMQ015-DIN8 CHTMH015-DIN10
	CHTGH020-Gauge	24*24*200L*M2	19°31'42"	CHTGH020-DIN5 CHTGH020-DIN6 MHTG020-DIN6
	MHTGQ020-JIS-Gauge	16*A25*195.75L*M2	21°30'	MHTGQ02010-JIS1
	CHTM020-Gauge	24*24*200L*M2	19°31'42"	CHTM020-DIN8 CHTMQ020-DIN8 CHTMH020-DIN10
M2.5	CHTM020-JIS-Gauge	25*25*195L*M2	15°	CHTM020-JIS4
	CHTGH025-Gauge	24*24*200L*M2	19°31'42"	CHTGH025-DIN5 CHTGH025-DIN6 MHTG025-DIN6
M3	MHTGQ025-JIS-Gauge	20*A30*194.12L*M2.5	21°30'	MHTGQ025-JIS1
	CHTGH030-Gauge	29*29*200L*M3	19°31'42"	CHTGH030-DIN5 CHTGH030-DIN6 MHTG030-DIN6
M4	MHTGQ030-JIS-Gauge	25*A35*192.47L*M3	21°30'	MHTGQ030-JIS1
	CHTM030-Gauge	30*A29*200L*M3	19°31'42"	CHTM030-DIN8 CHTMQ030-DIN8 CHTMH030-DIN10
	CHTM030-JIS-Gauge	35*35*195.2L*M3	15°	CHTM030-JIS4
M5	CHTGH040-Gauge	39*39*200L*M4	19°31'42"	CHTGH040-DIN5 CHTGH040-DIN6 MHTG040-DIN6
	CHTM040-Gauge	40*A39*200L*M4	19°31'42"	CHTM040-DIN8 CHTMQ040-DIN8 CHTMH040-DIN10
M6	CHTGH050-Gauge	49*A39*200L*M5	19°31'42"	CHTGH050-DIN5 CHTGH050-DIN6 MHTG050-DIN6
	CHTM050-Gauge	49*A39*200L*M5	19°31'42"	CHTM050-DIN8 CHTMQ050-DIN8 CHTMH050-DIN10
M8	CHTGH060-Gauge	59*A49*200L*M6	19°31'42"	CHTGH060-DIN5 CHTGH060-DIN6 MHTG060-DIN6
	CHTM060-Gauge	59*A49*200L*M6	19°31'42"	CHTM060-DIN8 CHTMQ060-DIN8 CHTMH060-DIN10
M10	CHTGH080-Gauge	79*79*186.66L*M8	19°31'42"	CHTGH080-DIN5 CHTGH080-DIN6 MHTG080-DIN6
	CHTM080-Gauge	79*79*186.66L*M8	19°31'42"	CHTM080-DIN8 CHTMQ080-DIN8 CHTMH080-DIN10
M10	CHTGH100-Gauge	99*99*200L*M10	19°31'42"	CHTGH100-DIN6
	CHTM100-Gauge	99*99*200L*M10	19°31'42"	CHTM100-DIN8 CHTMQ100-DIN8 CHTMH100-DIN10

JIS 系列以灰底做區隔，以便讀取。
JIS Series noted in gray for easy identification.

直齒齒規安裝規格表
Straight Rack Gauge for Assembling

模數 Module	型號 Code	規格 Dimension	適用齒條系列 Rack Code Matched
	直齒齒規 / Straight Gauge		
M1	CSTGH010-JIS2-Gauge	10*A12*197.92L*M1	CSTGH010-JIS2
M1.5	CSTGH015-Gauge	17*17*197.92L*M1.5	CSTGH015-DIN 6
	CSTGH015-JIS2-Gauge	15*A20*197.92L*M1.5	CSTGH015-JIS2
	CSTM015-Gauge	17*17*197.92L*M1.5	CSTM015-DIN8 CSTMQ015-DIN8 CSTMH015-DIN10
	CSTM015-JIS4-Gauge	15*A20*197.92L*M1.5	CSTM015-JIS4 CSTMH015-JIS5
M2	CSTGH020-Gauge	24*24*194.78L*M2	CSTGH020-DIN5 CSTGH020-DIN6
	CSTGH020-JIS2-Gauge	20*A25*194.78L*M2	CSTGH020-JIS2
	CSTM020-Gauge	25*A24*194.78L*M2	CSTM020-DIN8 CSTMQ020-DIN8 CSTMH020-DIN10
	CSTM020-JIS4-Gauge	20*A25*194.78L*M2	CSTM020-JIS4 CSTMH020-JIS5
M2.5	CSTGH025-Gauge	25*24*196.35L*M2.5	CSTGH025-DIN6
	CSTGH025-JIS2-Gauge	25*A30*196.35L*M2.5	CSTGH025-JIS2
	CSTM025-JIS4-Gauge	25*A30*196.35L*M2.5	CSTM025-JIS4 CSTMH025-JIS5
M3	CSTGH030-Gauge	29*29*197.92L*M3	CSTGH030-DIN5 CSTGH-030-DIN6
	CSTGH030-JIS3-Gauge	30*A35*197.92L*M3	CSTGH030-JIS2
	CSTM030-JIS4-Gauge	30*A35*197.92L*M3	CSTM030-JIS4 CSTMH030-JIS5
M4	CSTGH040-Gauge	39*39*188.49L*M4	CSTGH040-DIN5 CSTGH040-DIN6
	CSTGH040-JIS2-Gauge	40*A45*188.49L*M4	CSTGH040-JIS2
	CSTM040-Gauge	40*A39*188.49L*M4	CSTM040-DIN8 CSTMQ040-DIN8 CSTMH040-DIN10
	CSTM040-JIS4-Gauge	40*A45*188.49L*M4	CSTM040-JIS4 CSTMH040-JIS5
M5	CSTGH050-Gauge	49*A39*188.49L*M5	CSTGH050-DIN5 CSTGH060-DIN6
	CSTGH050-JIS2-Gauge	50*A50*188.49L*M4	CSTGH050-JIS2
	CSTM050-Gauge	49*A39*188.49L*M5	CSTM050-DIN8 CSTMQ050-DIN8 CSTMH050-DIN10
	CSTM050-JIS4-Gauge	50*A50*188.49L*M4	CSTM050-JIS4 CSTMH040-JIS5
M6	CSTGH060-Gauge	59*A49*188.49L*M6	CSTGH060-DIN6
	CSTGH060-JIS-Gauge	60*A60*188.49L*M4	CSTGH060-JIS2
	CSTM060-Gauge	59*A49*188.49L*M6	CSTM060-DIN8 CSTMQ060-DIN8 CSTMH060-DIN10
	CSTM060-JIS4-Gauge	60*A60*188.49L*M4	CSTM060-JIS4 CSTMH060-JIS5

直齒齒規安裝規格表
Straight Rack Gauge for Assembling

模數 Module	型號 Code	規格 Dimension	適用齒條系列 Rack Code Matched
	直齒齒規 Straight Gauge		
M8	CSTGH080-Gauge	79*79*175.92L*M8	CSTGH080-DIN6
	CSTM080-Gauge	79*79*175.92L*M8	CSTM080-DIN8 CSTMQ080-DIN8 CSTMH080-DIN10
M10	CSTM100-Gauge	99*99*188.496L*M10	CSTM100-DIN8 CSTMQ100-DIN8 CSTMH100-DIN10

周節 CP	型號 Code	規格 Dimension	適用齒條系列 Rack Code Matched
	直齒齒規 Straight Gauge		
CP 5	MSTGQ-CP050-GAUGE	15*20*200L*CP5	MSTGQ-CP050-JIS1 MSTGH-CP050-JIS1
	CSTM-CP050-GAUGE	15*20*200L*CP5	CSTM-CP050-JIS4
CP 10	MSTGQ-CP100-GAUGE	30*35*200L*CP10	MSTGQ-CP100-JIS1 MSTGH-CP100-JIS1
	CSTM-CP100-GAUGE	30*35*200L*CP10	CSTM-CO100-JIS4
CP 15	CSTM-CP150-GAUGE	50*50*195L*CP15	CSTM-CP150-JIS4
CP 20	CSTM-CP200-GAUGE	60*60*200L*CP20	CSTM-CP200-JIS4

JIS 系列以灰底做區隔，以便讀取。
JIS Series noted in gray for easy identification.

前言

本裝配說明指南適用於齒條的運輸、儲存、裝配、及保養，在所有相關專業人員從事並進行上述動作時，請先仔細並確實詳讀本說明書內容，若相關專業人員未仔細詳讀或不按相關操作規範進行齒條的運輸、儲存、裝配及保養而產生任何財產損失及人員受傷，本公司不負責任何賠償。

齒條安裝說明大綱

(一) 運輸

運輸過程勿不正確堆疊、大力摔放或不正常的吊掛造成齒條扭變或損傷。

(二) 儲存

齒條應儲存於乾燥環境中，且溫度應於 25°C，相對濕度 60% 最為適宜。並確實檢查齒條的包裝需完整，放置時應保持水平放置，避免傾斜、側放或直立放置。

(三) 裝配

齒條裝配請由經過合格訓練之專業人員來操作裝配，並確實準備相關裝配所需使用的器具。

(四) 保養事項

請依造齒輪齒條運行的方式來制定保養計畫。

※ 若有任何問題，請與我司聯繫。

齒條安裝操作說明

(一) 運輸

齒條於出廠時均經過整直，防鏽以及良好的包裝，使用熱縮膜來隔離空氣並保護齒條以避免碰撞。

本公司出產的齒條如果長度超過 1 米 (100cm) 或重量超過 10 公斤時，應由兩位或兩位以上的操作員協同搬運，可避免碰撞或不慎掉落。

若同時需搬運多支數量之齒條，請使用吊掛棧板，以避免工件滑落；並於吊掛工件時，隨時注意周邊環境避免工件掉落，或是碰撞周邊物品，而砸傷人員。

(二) 儲存

齒條應儲存於溫度適宜並且乾燥的環境中，溫度 25°C、相對濕度 60% 最為適宜，齒條要進行倉庫存放前，應確實檢查齒條外部包裝的完整性。

由於齒條出廠前均經過良好的防鏽處理，在齒條上均塗抹防鏽油，並經過熱縮膜的包裝，以隔絕空氣接觸，並防止碰撞；在儲存齒條的過程中，應避免傾斜或是直立的放置齒條。

放置齒條的場所，需維持適宜的溫度及濕度的穩定，並且放置時應保持場所的穩定避免震動。另外齒條平放時需避免任何不正常的堆疊，或是壓迫在齒條的上方，以避免齒條因外力壓迫而變形。

The instruction of installation is adapted for transportation, storage, assembly and maintenance of racks. All the relevant professionals should study carefully the content of the instruction before doing the actions as above. If any professionals don't study thoroughly nor follow up the regulations to do the actions of transportation, storage, assembly and maintenance of racks, any property damage or personal injury, we are irresponsible for any compensations.

OUTLINE OF RACK INSTALLATION INSTRUCTIONS

1. TRANSPORTATION

During transportation process, please do not stack incorrectly, vigorously put or hang racks to make it twisted or damaged.

2. STORAGE

Racks should be stored in dry environment with temperature 25 °C , and relative humidity should be 60% which is the best. To check the rack package should be completed and stored horizontally to avoid being sloping, leaning on one side or upright side.

3. ASSEMBLY

Rack assembly should be operated by well-trained and qualified professionals. Meanwhile, please prepare all the relevant tools accurately while assembling.

4. MAINTENANCES

Please set up maintenance plans based on the running methods of rack and pinions.

**If there are any questions, please kindly contact us.*

RACK INSTALLATION INSTRUCTIONS

1. TRANSPORTATION

All racks are straightened before delivering, and packed by thermal shrinkage film to isolate the air and to protect racks from collision.

If the rack length is over 1,000mm (100cm) or 10 kgs, is should be carried by 2 or more people to avoid collision or dropping.

If carrying plenty of racks, it should be hanged on a pallet to avoid racks dropping. During hanging, please pay attention to the surroundings to avoid dropping or colliding with somethings to injure people.

2. STORAGE

Racks should be stored in a suitable temperate and dry environment. The room temperature should be 25°C, and relative humidity should be 60% which is the best.

Before storage, the rack outside package should be inspected if completed.

Before delivering, all the racks are smeared anti-rust lubricant and packed by thermal shrinkage film to isolate air and prevent from collision. During the rack storage process, it should not be sloping, leaning on one side or upright side.

The rack storage place should be maintained in a suitable and stable temperature and humidity. Meanwhile, the place should be stable to avoid vibration.

Racks should be put on horizontally; prevent from any abnormally stacking, or oppress on the top of racks. So, the racks will not be twisted due to outside oppression.

To check the rack package should be completed and stored horizontally to avoid being sloping, leaning on one side or upright side.

(三) 裝配

3.1. 裝配操作前·檢查與準備

- 3.1.1 安裝齒條前請先確實檢查齒條外包裝的完整性，並在拆封齒條包裝時，請小心拆封，以避免齒條損傷。
- 3.1.2 安裝齒條前請先確認齒條的規格，並詳細檢查安裝時所需的安裝器具。

3. ASSEMBLY

3.1 Before assembly, check and prepare.

- 3.1.1 Before assembling racks, please do check the rack outside package and open the cartons carefully in case racks are damaged accidentally.
- 3.1.2. Before assembling racks, please check racks' specifications and all the necessary assembly tools carefully.



圖 1 / Fig.1

- 3.1.3 安裝齒條前，須確保基座安裝承靠面的垂直度及平行度需在要求內，一般要求平行度為 $\leq 0.02\text{mm}$ ，垂直度為 $\leq 0.02\text{mm}$ ，如圖 2 所示。

- 3.1.3 Before assembling, please assure the verticality and parallel of bearing surface of installation basement should be within the tolerance. The verticality is $\leq 0.02\text{mm}$ and parallel is $\leq 0.02\text{mm}$ as the Fig. 2 below.

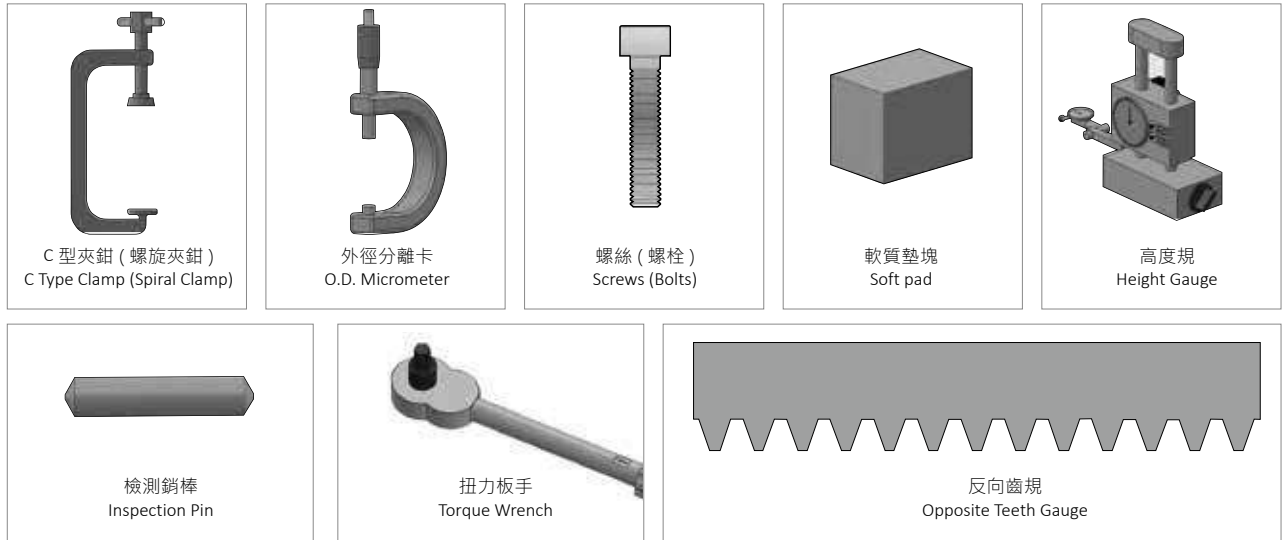

圖 2 / Fig.2

- 3.1.4 確實檢查齒條及基座安裝的承靠面的清潔及完整性，避免齒條及基座的接觸面有任何損傷或有殘餘毛屑。

- 3.1.4 Please do check the bearing surface of rack and installation base clean and complete to avoid any damage or chippings.

- 3.1.5 安裝承靠面底部的倒角面，需注意干涉問題如圖 3. 箭頭所示。

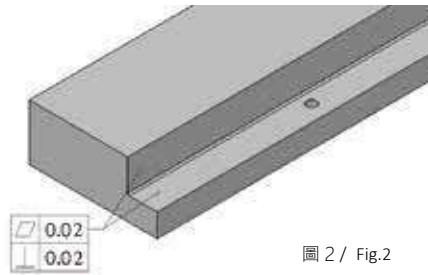
- 3.1.5 The chamfering surface of installation bearing surface bottom have to be aware of the question as Fig 3 noted.



齒條倒角尺寸須符合本公司要求的規範 (請參考表 1)
基座安裝承靠面的倒角量建議值最大不得超過 0.3mm。

注意



The rack chamfer angle should be apply with our standards (as chart 1).
The recommended chamfer value of bearing surface of installation base should not exceed 0.3 mm at maximum.

Attention



圖 3 / Fig.3

單位 / Unit : mm

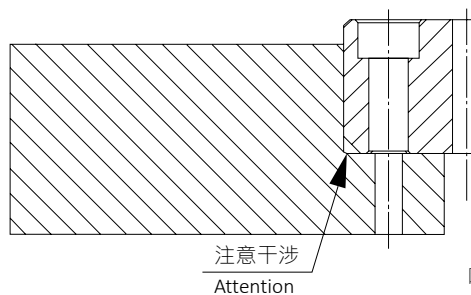
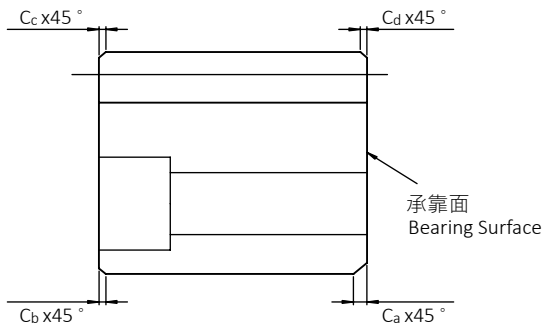

Rack	Ca	Cb	Cc	Cd
M1	1.5mm	0.5mm	0.5mm	0.5mm
M1.5	1.5mm	0.5mm	0.5mm	0.5mm
M2	2.0mm	1.0mm	1.0mm	1.0mm
M3	2.0mm	1.0mm	1.0mm	1.0mm
M4	2.0mm	1.5mm	1.5mm	1.5mm
M5	3.0mm	1.5mm	1.5mm	1.5mm
M6	3.0mm	2.0mm	2.0mm	2.0mm
M8	4.0mm	2.0mm	2.0mm	2.0mm
M10	5.0mm	3.0mm	3.0mm	3.0mm
M12	5.0mm	3.0mm	3.0mm	3.0mm

表 1 / Table 1

3.1.6 齒條的定位銷孔是專門提供齒條的重覆安裝時的快速定位使用，若非重覆安裝，則不需要安裝定位銷孔。

3.1.6 Rack positioning pin hole is specially for quick positioning purpose when racks are assembled repeatedly. If no repeated demands, it is not necessary to assemble positioning pin hole.

3.2. 裝配步驟 A- 單支齒條裝配

3.2. Assembly Process A- Single Rack Assembly

3.2.1 將齒條放於枕木上，將檢測銷棒放置齒條的齒谷內，使用外徑分離卡檢測跨銷值，如圖 4。

3.2.1 Put the rack on the blocks; put the inspection pin in the rack valley of the teeth and use O.D. micrometer to check the over pin value as Fig 4.



圖 4 / Fig.4

★齒條安裝前，請參考圖 4 的量測方式，確定齒條的跨銷值在精度等級內。

★ Before assembling racks, please refer to the inspection method on Fig. 4 and assure the over-pin values of rack are within the quality grade tolerance.

跨銷值計算公式：

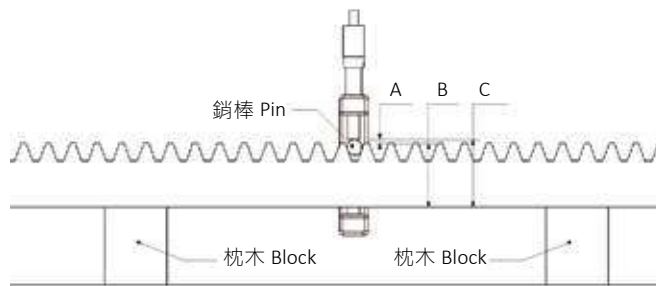
跨銷值 C= 數值 A+ 齒條總高度 B

Over-Pin Value Formula:

Over-Pin Value C= Value A + Total Rack Height B

※ 檢測銷棒數值請參考表 2。

※ Please refer to Chart 2 for inspection over-pin value.



注意

檢測銷棒建議直徑公差於 $0 \geq -0.001\text{mm}$ 的檢測為最佳精準度。



Attention

The best tolerance of inspection pin diameter is $\geq -0.001\text{mm}$.

單位 / Unit : mm

模數 Module	數值 Value	檢測銷棒 Inspection Pin	齒距 Pitch	
			斜齒 Helical (19°31'42")	直齒 Straight
M1.0	0.766	ψ2	3.333	3.142
M1.5	1.149	ψ3	5.000	4.712
M2.0	1.532	ψ4	6.667	6.283
M3.0	2.298	ψ6	10.000	9.425
M4.0	3.064	ψ8	13.333	12.566
M5.0	3.830	ψ10	16.667	15.708
M6.0	4.596	ψ12	20.000	18.850
M8.0	6.128	ψ16	26.667	25.133
M10.0	7.659	ψ20	33.333	31.416

表 2 / Table 2

3.2.2 齒條置放於基座承靠面上，對齊螺絲孔距，微擰螺絲至沉頭螺絲孔接觸面，如圖 5 所示。

3.2.2 The rack is put on the top of the base of the bearing surface. Align the screw holes pitches. Slightly tighten the screws to the contact surface of countersunk head screw hole as the Fig. 5 as below.

3.2.3 將 C 型夾鉗墊上軟質墊塊，再將齒條頭尾兩端使用 C 型夾鉗固定，中間平均固定全部齒條與基座，讓齒條與基座承靠面完全貼合。(如圖 6 示)

3.2.3 Place the C-type clamp on the soft pad, then fix the two ends of the racks by the C-type clamp. Fix the middle of the rack averagely on the base to assure the whole rack is attached to the bearing surface of the base completed as Fig. 6 below.

3.2.4 將檢測銷棒平均放置於齒條前中後五個檢測點，使用高度規測量檢測銷棒的最高點，檢測數值須與步驟 2.1 所得之數值一致，如檢測出的數值不同，則將 C 型夾鉗夾緊，調整至與步驟 2.1 量測量出的數值一致即可，如圖 7。

3.2.4 Place inspection pins averagely on the 5 inspection points of the rack. Use height gauge to measure the highest point of the inspection pins. The inspected values should be the same as step 3.2.1. If the values are different, please tighten the C-type clamp and fix the values to the same as step 3.2.1. as Fig. 7 below.

3.2.5 將螺絲(螺栓)由中間端開始固定再往兩側擰緊。



圖 5 / Fig.5



圖 6 / Fig.6



圖 7 / Fig.7

3.2.6 將 C 型夾鉗與軟性墊塊移除。

3.2.5 Fix the screws (bolts) from the middle; then onward to the two ends of the racks.

3.2.6 Remove the C-type clamp and soft pads.

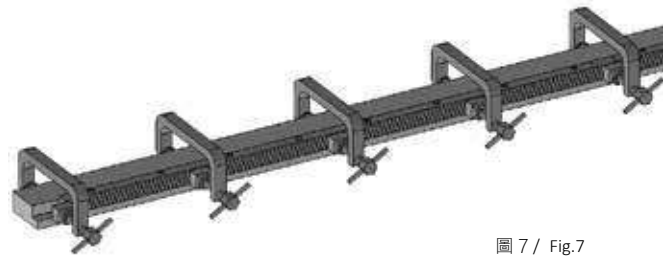
3.3. 裝配步驟 B- 多支齒條裝配步驟

3.3. Assembly Process B- Multiple Racks Assembly

3.3.1 兩支或兩支以上齒條的裝配，裝配步驟依照裝配步驟 A- 單支齒條裝配的方式裝配，相接處需增加相接輔助器具反向齒規，作為銜接咬合之標準，以防止齒距誤差過大(如圖 8)。

3.3.1 Two or more racks assembly, please follow up the assembly process A-single rack assembly. Between racks joint point, it's necessary to increase an assistive device, opposite teeth gauge as the standard of joining racks up, to avoid pitch error too large. (Fig. 8)

微擰螺絲後撤掉齒規(如圖 9)，將檢測銷棒放置於左右相接處的齒谷內(如圖 10)，微調相接的兩支齒條，使用高度規量測檢測銷棒最高點的數值(如圖 10；ABC 三點)，使其三點數值與前面步驟 2.1 用外徑分離卡檢測之數值相同(圖 12)。

Slightly tighten screws and remove opposite teeth gauge as Fig 9, and place the inspection pin on the teeth valley of the joint point (Fig.10). Slightly adjust the jointing two racks and use height gauge to measure the highest point values of the inspection pin(Fig 10/A,B,C points). The values of the three points should be the same as step 3.2.1, using O.D. micrometer to measure. (Fig. 12)

使用 C 型夾鉗墊上軟質墊塊將齒條固定於基座，再使用扭力扳手依序將固定螺絲鎖緊(圖 13)，螺絲(螺栓)扭力值可參考表 3。待鎖緊後，撤掉測量銷棒、C 型夾鉗及軟質墊塊，即完成裝配步驟(圖 14)。

Use C-type clamp and place the soft pads on the rack base. Then, use torque wrench in sequence to fix and tighten screws(bolts). The screw torque values could be referred to Table 3. (Fig. 13) After tightening, remove the inspection pins, C-type clamp and soft pads. The assembly step is completed. (Fig. 14)



注意 三根齒條以上裝配，需由基座中央開始向兩側銜接裝配。



Attention Three racks above assembly, it starts from the middle base, and onwards to the ends.

3.3.1 高度規量測檢測銷棒最高點的數值，量測的數值須與前面步驟 3.2.1 用外徑分離卡檢測之數值相同。

3.3.1 Measure the highest point of the inspection pin by height gauge. The measured values should be the same as the values by OD micrometer as step 3.2.1.

3.3.2 相接處需使用相接輔助器具反向齒規，作為銜接咬合之標準，以防止齒距誤差過大，如圖 8。

3.3.2 The two joint sides should be placed on the assistive device, opposite teeth gauge as the standard of joining racks up. to avoid pitch error too large. (Fig. 8)



圖 8 / Fig.8

3.3.3 微擰螺絲後撤掉齒規，如圖 9

3.3.4 檢測銷棒放置於 A、B、C 三點做檢測，如圖 10。

3.3.3 Slightly loose screws and remove the opposite teeth gauge. Fig 9.

3.3.4 Place the inspection pins on A, B, C three points. As Fig 10.



圖 9 / Fig.9



圖 10 / Fig.10

3.3.5 使用高度規量測檢測銷棒最高點的數值，使其三點檢測銷棒最高點數值與前面步驟 1 之數值相同，若中間檢測銷棒的最高點數值與左右兩支檢測銷棒最高點數值不同，可左右微調相接處齒條，得到三點檢測銷棒最高點之相同數值，如圖 11。

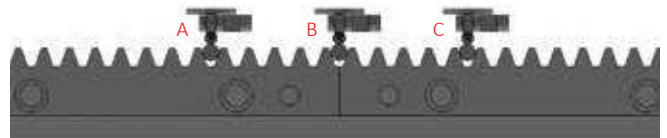

圖 11 / Fig.11

3.3.5 Measure the values of the 3 highest points of the inspection pins by height gauge to assure the 3 values are the same as on Step 1. If values are different, slightly adjust the two jointed racks, to make the value of the highest point of inspection pin is the same as step 1. Fig11.

3.3.6 量測正確的檢測銷棒最高點數值後，使用 C 型夾鉗墊上軟質墊塊，將齒條固定於基座，再使用扭力扳手依序將固定螺絲鎖緊，如圖 12。

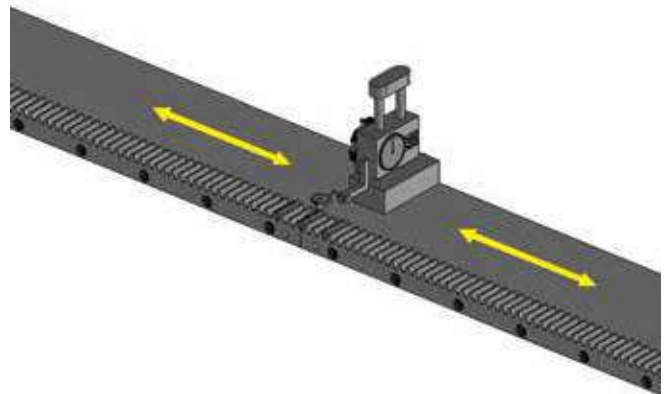

圖 12 / Fig.12

3.3.6 Measure the correct value of the highest inspection pin; use C-type clamp and place soft pads to fix the rack on the base. Then, use torque wrench in sequence to fix and tighten screws as Fig. 12.

3.3.7 螺絲鎖緊後移除 C 型夾鉗、軟質墊塊，完成裝配，如圖 13。



圖 13 / Fig.13

3.3.7 Tighten screws and remove C-type clamp, soft pads. The assembly is completed. As Fig 13.

螺絲規格 Screw Spec.	六角扳手 Hex Wrench (mm)	強度 12.9 Torque Value (N.m)
M4*0.7P	3	4.3
M5*0.8P	4	7.5
M6*1.0P	5	13.4
M8*1.25P	6	30.5
M10*1.5P	8	61
M12*1.75P	10	102
M14*2.0P	12	162
M16*2.0P	14	249
M20*2.5P	17	481
M24*3.0P	19	836
M30*3.5P	22	1670

表 3 螺絲扭力值 / Table 3. Screw Torque

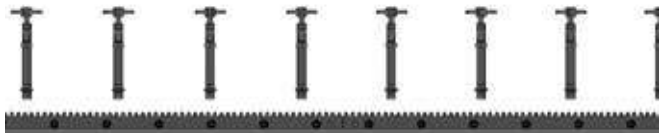

圖 14 / Fig.14

3.4. 裝配完成檢查

- 3.4.1 清潔附著於齒面上防鏽油。
- 3.4.2 於齒面上塗抹有色塗料如：黃丹、紅丹或藍丹亦可（請勿塗抹無法清除之漆料）。
- 3.4.3 於齒條運作範圍內，齒輪反覆來回移動嚙合。
- 3.4.4 觀看齒面塗抹有色顏料的脫落情況，如圖 14 所示。
- 3.4.5 齒面嚙合狀況正確，則清除附著於齒面的有色塗料，裸露部分請塗抹防鏽油脂，若非正確請調整至正確狀況。

3.5. 運行前注意事項

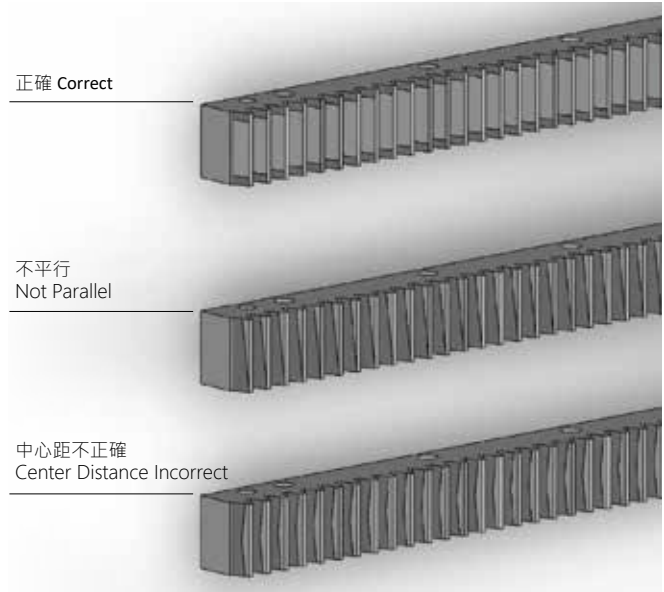
- 3.5.1 齒條裝配無誤，齒面嚙合情況正確。
- 3.5.2 齒條與齒輪嚙合面須有適合之潤滑油脂。
- 3.5.3 運行範圍裡確定無人員，避免造成傷害。

(四) 保養

- 4.1 依照設備運作情況制定保養計畫表。
- 4.2 潤滑油脂請選用適當之油脂，依照選用之油脂決定潤滑之設備。
- 4.3 保養周期視磨耗情形增長或縮短計畫。
- 4.4 齒條若磨損嚴重或崩裂，請更換齒條，避免影響運行精度效能。

※ 齒條拆卸與保養請由經過訓練的人員進行處理。

3.4. Inspection After Assembly.

- 3.4.1 Clean the lubricant oil on the racks.
- 3.4.2 Smear colored paint on racks such as lead oxide elow powder, red powder and blue powder. (Please use clearable paints).
- 3.4.3 Inside the rack movement, the pinion runs back and forth to clench.
- 3.4.4 Observe the peeling situation on the painted teeth of the racks as Fig.14.
- 3.4.5 If teeth clenches correctly, please clean the colored paint on the racks. Bare parts should be smeared anti-rust lubricant. If not correctly, please adjust it to correct.

3.5. Attentions by Operation

- 3.5.1 Racks Assembly correct. Teeth clench correct.
- 3.5.2 The clenching surface of rack and pinion needslubricant oil.
- 3.5.3 Assure no people inside the operation area to avoid any injure.

4. Maintenances

- 4.1 Formulate a maintenance schedule according to theequipment operation situation.
 - 4.2 Please select suitable lubricant oil and decide lubricant system according to the lubricant oil.
 - 4.3 Maintenance cycle should be increased or decreased, based on operation worn situation.
 - 4.4 If racks are worn or damaged seriously, please replace new racks to avoid any impact on operation accuracy and efficiency.
- ※Rack replacement and maintenance should be operated by trained and qualified professionals.



SINCE 1980



原億昌機械股份有限公司

- ◆台灣41469台中市烏日區
溪南路三段752號
- ◆電話: +886 4 23357828
- ◆傳真: +886 4 23356732
- ◆<https://www.yycdrives.com>

Yuan Yi Chang Machinery Co., Ltd.

- ◆No. 752, Sec. 3, Xinan Rd., Wuri Dist.,
Taichung City 41469, Taiwan
- ◆TEL: +886 4 23357828
- ◆FAX: +886 4 23356732
- ◆E-mail: info@yycdrives.com